



# Ruijie RG-CS86-20XS Series Switches

## Hardware Installation and Reference Guide

Document Version: V1.1  
Date: 2023.11.30  
Copyright © 2023 Ruijie Networks

## Copyright

Copyright © 2023 Ruijie Networks

All rights are reserved in this document and this statement.

Any reproduction, excerpt, backup, modification, transmission, translation or commercial use of this document or any portion of this document, in any form or by any means, without the prior written consent of Ruijie Networks is prohibited.

Trademark  and  are owned by Ruijie Networks.

All other trademarks or registered trademarks mentioned in this document are owned by their respective owners.

## Disclaimer

The products, services, or features you purchase are subject to commercial contracts and terms. Some or all of the products, services or features described in this document may not be within the scope of your purchase or use. Unless otherwise agreed in the contract, Ruijie Networks does not make any express or implied statement or guarantee for the content of this document.

Due to product version upgrades or other reasons, the content of this document will be updated from time to time. Ruijie Networks reserves the right to modify the content of the document without any notice or prompt.

This manual is for reference only. Ruijie Networks endeavors to ensure content accuracy and will not shoulder any responsibility for losses and damages caused due to content omissions, inaccuracies or errors.

# Preface

## Intended Audience

This document is intended for:

- Network engineers
- Technical support and servicing engineers
- Network administrators

## Technical Support

- Ruijie Networks website: <https://www.ruijienetworks.com/>
- Technical support website: <https://ruijienetworks.com/support>
- Case portal: <https://caseportal.ruijienetworks.com>
- Community: <https://community.ruijienetworks.com>
- Technical support email: [service\\_rj@ruijienetworks.com](mailto:service_rj@ruijienetworks.com)
- Skype: [service\\_rj@ruijienetworks.com](https://www.skype.com/people/service_rj@ruijienetworks.com)

## Conventions

### 1. Conversions

Convention	Description
<b>Bold font</b>	Commands, command options, and keywords are in <b>bold</b> font.
<i>Italic font</i>	Arguments for which you supply values are in <i>italic</i> font.
[ ]	Elements in square brackets are optional.
{ x   y   z }	Alternative keywords are grouped in braces and separated by vertical bars.
[ x   y   z ]	Optional alternative keywords are grouped in brackets and separated by vertical bars.
&<1-n>	The argument before the sign (&) can be input for consecutive 1- n times.
//	Double slashes at the beginning of a line of code indicate a comment line.

### 2. Signs

The signs used in this document are described as follows:

---

 **Warning**

An alert that calls attention to important rules and information that if not understood or followed can result in data loss or equipment damage.

---

---

 **Caution**

An alert that calls attention to essential information that if not understood or followed can result in function failure or performance degradation.

---

---

 **Note**

An alert that contains additional or supplementary information that if not understood or followed will not lead to serious consequences.

---

---

 **Specification**

An alert that contains a description of product or version support.

---

### 3. Note

The manual offers configuration information (including model, port type and command line interface) for indicative purpose only. In case of any discrepancy or inconsistency between the manual and the actual version, the actual version prevails.

# 1 Product Overview

The RG-CS86-20XS4VS2QXS-D switch is a next-generation L3 switch featured with high performance, high security and multiple services. Mainly applied to the aggregation layer of the campus network, the switch provides multi-layer switching at full line rate and complete end-to-end Quality of Service (QoS) policies, assigning different service flow with different bandwidth and ensuring no delay for key service flow. RG-CS86-20XS4VS2QXS-D provides 20 10G SFP+ ports, four 25G SFP28 ports and two 40G QSFP+ ports.


Model	100G QSFP28 Port	40G QSFP+ Port	25G SFP28 Port	10G SFP+ Port	100M/1G/2.5G/5G/10G Ethernet Port	Fan Redundancy	Power Redundancy
RG-CS86-20XS4VS2QXS-D	-	2	4	20	20	2	1+1

- i** All 25G/10G SFP28 ports must work at the same rate, either 25G or 10G.
- i** 25G SFP28 ports working in 25G support SFP modules and do not support DAC cables. Please see Appendix B for supported models and specifications.
- i** 40G QSFP+ ports of RG-CS86-20XS4VS2QXS-D support both 40G mode and 4x10G mode.
- i** 10G SFP+ ports of RG-CS86-20XS4VS2QXS-D support both 10Gbase-R and 1000base-X. 10G SFP+ ports working in 1000base-X support auto-negotiation.
- i** SFP+ ports of RG-CS86-20XS4VS2QXS-D support 2.5G.

## 1.1 RG-CS86-20XS4VS2QXS-D

### Specifications

Model	RG-CS86-20XS4VS2QXS-D
CPU	ARM CPU, each core with the clock speed of 1.25 GHz
BOOT ROM	16MB
Flash Memory	1GB
RAM	1GB, 32-bit wide + 4-bit ECC
Expansion Module Slot	Unsupported
Fan Slot	2 (Two fans are required.)
Fan Module	M1SFANI-F
Power Supply Slot	2
Power Module	RG-PA150I-F

Power Supply Input	AC input Rated voltage: 100 VAC to 240 VAC Maximum voltage: 90 VAC to 264 VAC Rated frequency: 50 Hz to 60 Hz Rated input current: <3 A@90~264 VAC@full load	High voltage direct current (HVDC) input: Rated voltage: 240 VDC Rated voltage: 192 VDC to 288 VDC Rated input current: 3 A
Power Consumption	< 85 W	
Optical Module	Refer to Appendix B  The supported modules may update at any time. Please contact Ruijie Networks for details.	
Temperature Warning	Support temperature warning and overheat protection.	
EMC	GB/T 9254.1	
EMI	GB 4943.1	
Altitude	0 to 5000 m (16404.2 feet)	
Working Temperature	0°C to 50°C (32°F to 122°F) The temperature decreases by 1°C (1.8°F) as the altitude ranging from 3000m (9842.52 feet) to 5000 m (16404.2 feet) increases by 220m (721.78 feet).	
Storage Temperature	-40°C to 70°C (-40°F to 158°F)	
Working Humidity	10% to 90% RH ( non-condensing)	
Storage Humidity	5% to 95% RH (non-condensing)	
Weight (With two fans and Without the power module)	4.6 kg (10.14 lbs, with two fan modules)	
Dimensions (W x D x H)	440 mm x 330 mm x 43.6 mm (17.32 in. x 12.99 in. x 1.72 in.), 1RU	

 In a domestic environment, this product may cause radio interference.

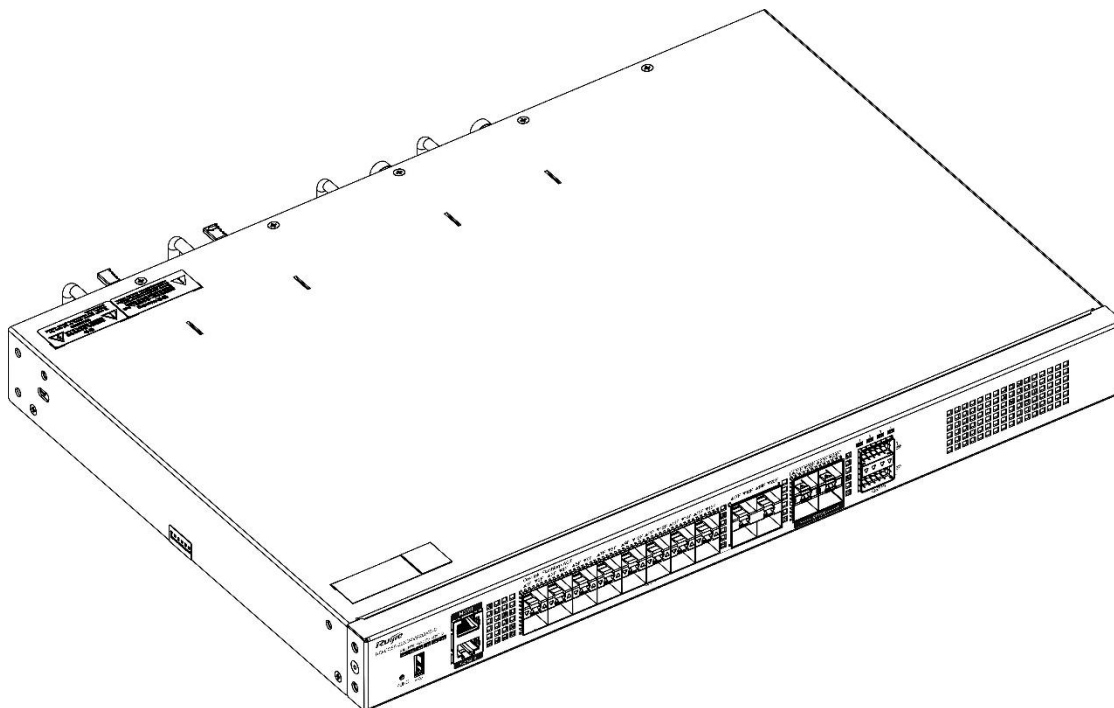
 This device is not suitable for use in locations where children are likely to be present.

 If a fan module fails at a temperature of lower than 27°C (80.6°F), please replace the fan within 24 hours and make sure that the faulty fan module is in place before replacement. If the temperature is higher than 27°C (80.6°F), please replace the fan immediately.

## Appearance

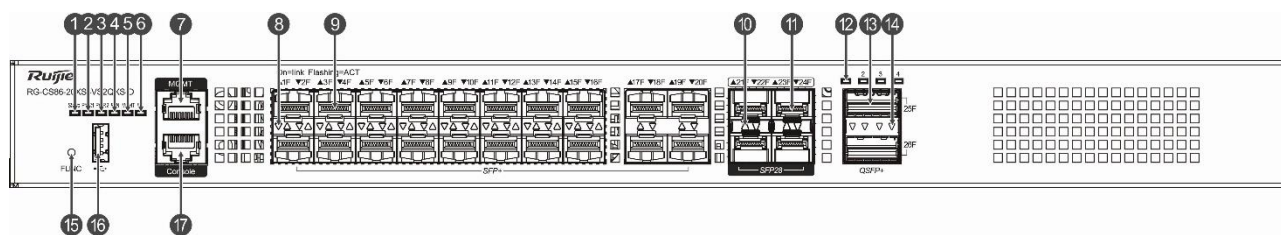
The RG-CS86-20XS4VS2QXS-D switch provides 20 10G SFP+ ports, four 25G SFP28 ports, two 40G QSFP+ ports, one MGMT port, one USB port, one Console port, two power slots and two fan slots.

Figure 1-1 Appearance of RG-CS86-20XS4VS2QXS-D



## Front Panel

Figure 1-2 Front Panel of RG-CS86-20XS4VS2QXS-D



- Note:
- |                        |                          |
|------------------------|--------------------------|
| 1. System indicator    | 10. SFP28 port indicator |
| 2. PWR1 indicator      | 11. SFP28 port           |
| 3. PWR2 indicator      | 12. QSFP+ port indicator |
| 4. Fan indicator       | 13. QSFP+ port           |
| 5. MGMT port indicator | 14. QSFP+ port indicator |
| 6. Locator indicator   | 15. FUNC button          |
| 7. MGMT port           | 16. USB port             |
| 8. SFP+ port indicator | 17. Console port         |
| 9. SFP+ port           |                          |

## Rear Panel

Figure 1-3 Rear Panel of RG-CS86-20XS4VS2QXS-D






- MGMT port: This is an out-band Ethernet port, which uses standard RJ45 connector. This interface is connected with Ethernet port of a PC to perform program downloading.
- SFP+ port: There are 20 10G/2.5G/1G SFP+ ports, which support optical modules and DAC copper cables, and are compatible with 1000BASE-X.
- SFP28 port: There are four 25G/10G SFP28 ports, which support 25G SFP28 modules, 10G SFP28 modules/DAC copper cables and do not support 25G copper cables. All 25G/10G SFP28 ports must work at the same rate, either 25G or 10G.
- QSFP+ port: There are two 40G QSFP+ ports, which support 40G QSFP+ modules and DAC copper cables. The port can work in 4x10G mode.

## Button

The RG-CS86-20XS4VS2QXS-D switch provides a FUNC button for resetting the switch.

-  Press the FUNC button and the system will start collecting information. After collection finishes, the switch will be reset automatically. Long press and short press both work.

## Indicator

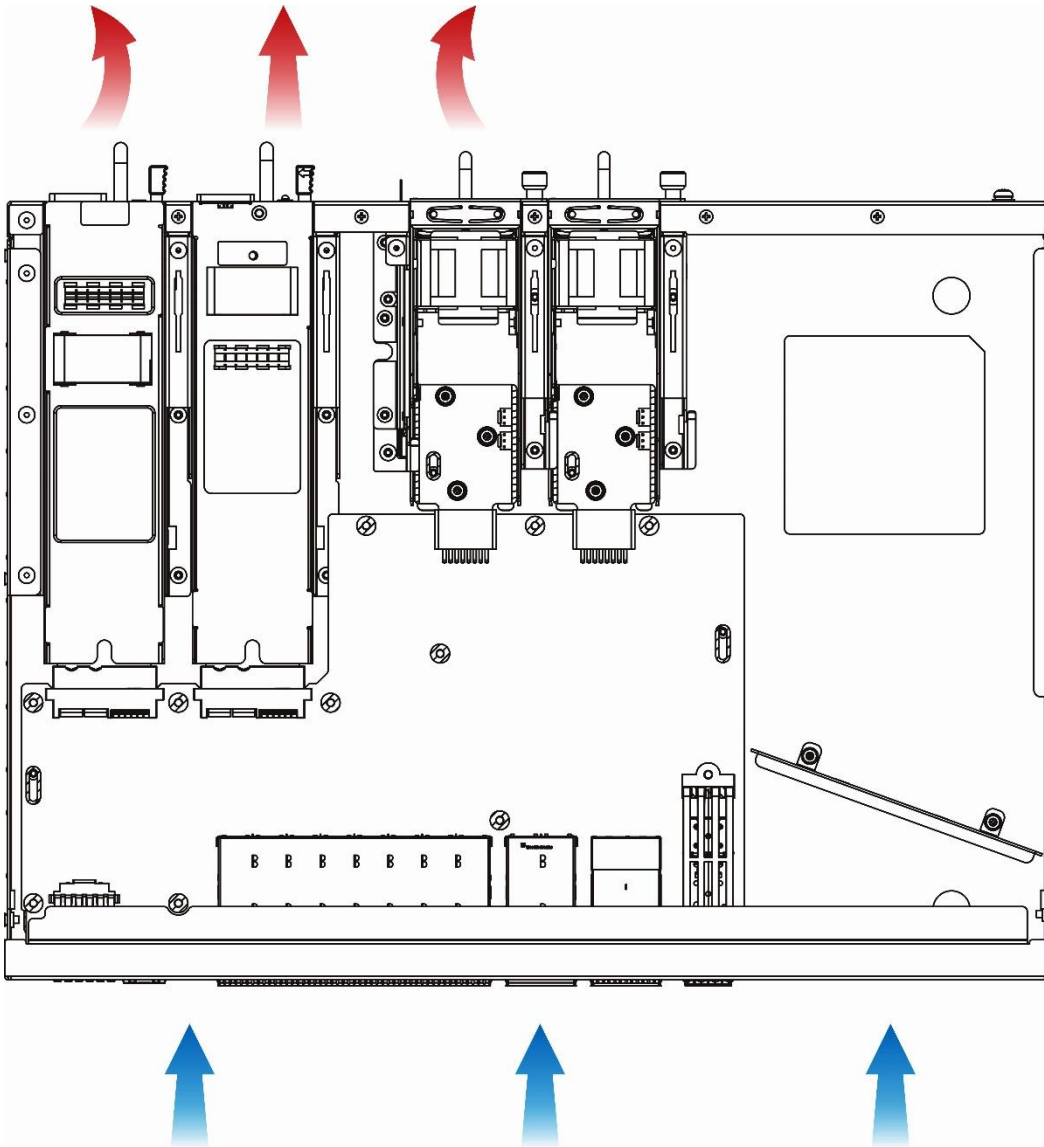
Indicator	Identification on the panel	Status	Meaning
System indicator (Front panel/rear panel)	Status	Off	The system is powered off.
		Solid red	1) A system fault occurs. 2) The temperature reaches the upper limit.
		Blinking green	Initialization is in progress.
		Solid green	The system works properly.
		Solid yellow	The temperature reaches the threshold value.
Power 1 indicator	PWR1	Off	The power module is NOT in the position.
		Solid green	The power module works properly.
		Solid red	A power fault occurs.
Power 2 indicator	PWR2	Off	The power module is NOT in the position.
		Solid green	The power module works properly.
		Solid red	A power fault occurs.
Fan indicator	FAN	Solid green	The fan works properly.
		Solid red	1) A fan fault occurs. 2) The fan model does not match with the system. 3) Not all fans are in position.
MGMT port indicator	MGMT	Off	The MGMT port is NOT connected.
		Green	The MGMT port is connected.
		Blinking green	The MGMT port is transmitting or receiving data.
Locator indicator	ID	Off	The locator is controlled by CPLD by default.
		Solid blue	The locator is controlled by O&M personnel remotely.
SFP+ port indicator	1F-20F	Off	The SFP+ port is NOT connected.
		Solid green	The SFP+ port is connected at 10G/2.5G/1G.

		Blinking green	The SFP+ port is transmitting or receiving data at 10G/2.5G/1G.
SFP28 port indicator	21F-24F	Off	The SFP28 port is NOT connected.
		Solid green	The SFP28 port is connected at 25G/10G.
		Blinking green	The SFP28 port is transmitting or receiving data at 25G/10G.
QSFP+ port indicator (40G mode)	25F-26F Indicator 1	Off	The QSFP+ port is NOT connected.
		Solid green	The QSFP+ port is connected at 40G.
		Blinking green	The QSFP+ port is transmitting or receiving data at 40G.
QSFP+ port indicator (4x10G mode)	25F-26F Indicator 1/2/3/4	Off	The QSFP+ port is NOT connected.
		Solid green	The QSFP+ port is connected at 10G.
		Blinking green	The QSFP+ port is transmitting or receiving data at 10G.

### Heat Dissipation

The RG-CS86-20XS4VS2QXS-D switch draws air from bottom to top using the rear panel fan to ensure that the device works properly in the specified environment. Make sure to maintain a minimum distance of 100 mm around the device for ventilation.

Figure 1-4 Heat Dissipation




## 1.2 Power Module

### 1.2.1 RG-PA150I-F

The RG-CS86-20XS4VS2QXS-D switch supports RG-PA150I-F. RG-PA150I-F is a smart power module and supports communication with the switch and asset management, including model, version number and SN. The power module can be hot swapped and supports asset management, including model, version number and SN.

- i** The RG-CS86-20XS4VS2QXS-D switch supports 1+1 power redundancy. To improve the stability and reliability, it is recommended to configure 1+1 power redundancy. When the two power modules work normally, the switch is in the status of current sharing.
- i** The system requires at least one power module. Please install a blank panel in each vacant slot to maintain proper cooling and air flow throughout the system.

Power Model	RG-PA150I-F (AC input)	RG-PA150I-F (HVDC input)
Rated Voltage	100 VAC to 240 VAC 50/60 Hz	240 VDC
Maximum Voltage	90 VAC to 264 VAC 47/63 Hz	192 VDC to 288 VDC
Input Current	3 A Max	
Output Voltage	12 V	
Max Current Output	12.5 A	
Max Power Output	150 W	
Input Leakage Current	≤ 3.5 mA	
Dimensions (L x W x H)	196 mm x 50.5 mm x 40 mm (7.72 in. x 1.99 in. x 1.57 in.)	
Weight	0.55 kg (1.21 lbs.)	
Temperature	Operating temperature: -10°C to 55°C (14 °F to 131 °F) Storage temperature: -40°C to 70°C (-40 °F to 158 °F)	
Humidity	Operating humidity: 5% to 95% Storage humidity: 5% to 95%	
Altitude	0 to 5,000 m	

 When you plug a power cord, install the power cord retainer on the power cord correctly to prevent the cord from loosening.

 Power cords should be connected to a grounded output socket.

## Features



Feature	Description
Conformal Coating	Protects circuits against moisture, frog, mould, electrical shock and leakage, and so on.
Protection	Provides protection over over-voltage/current input/output, short-circuit output and so on.
I2C Communication	Allows the host to communicate with the power module by I2C.
Power Supply Redundancy	Supports dual power modules to cooperate in parallel, enabling PE with 1+1 redundancy and redundant power supplies with current sharing.
Hot Swapping	Supports disconnection of one redundant power module from the outside power supply system. Plug and unplug power modules while the device is powered on.
Power Supply Alarm	Alarms power supply faults through the power indicator.

## Indicator

Indicator	State	Meaning
Output Status	Off	There is no power output or an output error occurs.
	On	Output is OK.

## 2 Preparation before Installation




## 2.1 Safety Precautions

-  To avoid body injury and device damage, please carefully read the safety precautions before you install the RG-CS86-20XS4VS2QXS-D switch.
-  The following safety precautions do not cover all possible dangers.


### 2.1.1 Installation






- Keep the chassis clean and dust-free.
- Do not place the device in walking areas.
- Do not wear loose clothes, ornaments or any other things that may be hooked by the chassis during the installation and maintenance.
- Turn off all power supplies and unplug all power cords and cables before the installation or the dismantling.

### 2.1.2 Removal

- Avoid frequent removals after the device is installed.
  - Turn off all power supplies and unplug all power cords and cables before the installation or the dismantling.
  - When removing the device, pay attention to the balance and avoid hurting legs and feet or straining the back.
-  When the device is being removed, do not hold the power supply handle or the fan handle for these parts are not designed for bearing the entire weight of the device. It will cause damage to the device or to your body if you hold these parts when removing the device.
-  To reduce the weight of the chassis during the removal, dismantle the expansion module, fan module and the power supply module first.
-  Install and operate the device in places where removing is restricted.

### 2.1.3 Electricicity

- Connect the device to a grounded output socket by a power cord.
  - For pluggable devices, the socket should be easily accessible.
  - Observe local regulations and specifications when electric operations are performed. Relevant operators must be qualified.
  - Carefully check any potential danger in the working area, such as ungrounded power supply, unreliable grounding of the power supply, and damp/wet ground.
  - Find out the location of the emergency power supply switch in the room before installation. First cut off the power supply in the case of an accident.
  - Be sure to make a careful check before you shut down the power supply.
  - Do not place the device in a damp location. Do not let any liquid enter the chassis.
-  Any nonstandard and inaccurate electrical operation can cause accidents such as fires or electrical attacks, thus causing severe, or even fatal damages to human bodies and the devices.

- 
-  Direct or indirect touch through a wet object on high-voltage and mains supply can bring a fatal danger.
  -  The RG-CS86-20XS4VS2QXS-D switch has more than one input power supply. Please unplug all power cables after powering off the switch.
  -  If a power supply system is equipped with a leakage protector (also referred to as "leakage current switch" or "leakage current breaker"), the rated leakage action current of each leakage protector is greater than twice of the theoretical maximum leakage current of all the power supplies in the system. For example, if a system is equipped with 16 identical power supplies, the leakage current of each power supply is equal to or less than 1.75 mA, and the leakage current of the system totals 28 mA. A leakage protector with 30 mA rated action current supports less than nine power supplies (that is, Action current of the leakage protector/2/Maximum leakage current of each power supply =  $30/2/1.75 = 8.57$ ). In other words, the leakage protector with 30 mA rated action current supports no more than eight power supplies. In this case, the 16 power supplies in the system require at least two leakage protectors with 30 mA rated action current and each leakage protector supports eight power supplies. If power supplies in a system differ in models, the rated leakage action current of each leakage protector divided by two is greater than the sum of maximum leakage currents of all the power supplies. The rated leakage non-action current of a leakage protector shall be 50% of the leakage action current. Take a leakage protector with 30 mA rated leakage action current as an example. The rated leakage non-action current shall be 15 mA. When the leakage current is below 15 mA, the protector shall not act. Otherwise, misoperation may easily occur due to high sensitivity and thus the leakage protector trips, devices are powered off, and services are interrupted.
  -  To guarantee personal safety, the rated leakage action current of each leakage protector in the system must be equal to or less than 30 mA (human body safety current is 30 mA). When twice of the total leakage current of the system is greater than 30 mA, the system must be equipped with two or more leakage protectors.
  -  For the leakage current value of each power supply model, see the power supply model parameter table in Chapter 1.
- 

#### 2.1.4 Electrostatic Discharge Damage Prevention

The RG-CS86-20XS4VS2QXS-D switch adopts multiple measures to prevent electrostatic discharge damage. But if the electrostatic exceeds certain limit, it can still cause great damages to the circuitry and the device. In networks connected by the RG-CS86-20XS4VS2QXS-D switch, the major sources of electrostatic induction include outdoor high voltage transmission cables, lightning, indoor floor materials and the machine structure.

- The device and the floor are well grounded.
- Take dust prevention measures in the room.
- Maintain an appropriate humidity.
- When the pluggable modules of the switch are being installed, wear anti-static wrist strap and make sure the anti-static wrist strap is well grounded.
- Do not use bare hand to directly touch the components and the printed-circuit board (PCB) when the boards are used.
- Use an anti-static shielding bag to properly store the board.
- Do not let any clothes touch a circuit board. An anti-static wrist strap can only prevent human static electricity from damaging the circuit board, but cannot prevent any static electricity on clothes.


#### 2.1.5 Laser

Among the modules supported by the RG-CS86-20XS4VS2QXS-D switch, there are a great number of optical modules that are Class I laser product.

Precautions:

- When a fiber transceiver works, ensure that the port has been connected with a fiber or has been covered by a dust cap so as to keep out dust and prevent it from burning your eyes.
- Do not stare at any fiber port.

---


 Do not stare at any fiber port under any circumstances, as this may cause permanent damage to your eyes.

---

### 2.1.6 Storage

To ensure the normal operation of the device, maintain a proper storage environment in accordance with storage temperature or humidity requirements according to the **Specifications** table.

---

 If the device storage time exceeds 18 months, you must power on the device and keep it running for 24 hours continuously.

---

## 2.2 Installation Site Requirements

Install the RG-CS86-20XS4VS2QXS-D switch indoors. To ensure normal operation and a prolonged service life of the device, the installation site must meet the following requirements.

### 2.2.1 Rack Mounting

Make sure the cabinet comply with the following conditions if the RG-CS86-20XS4VS2QXS-D switch is installed in the cabinet:

- Install the switch in an open cabinet as much as possible. If you install the switch inside a closed cabinet, be sure that the cabinet has a good ventilation and heat dissipation system.
- Be sure that the cabinet is firm enough to bear the weight of the RG-CS86-20XS4VS2QXS-D switch and its installation accessories.
- Be sure that the dimensions of the cabinet is appropriate for installation of the RG-CS86-20XS4VS2QXS-D switch that can reserve a certain space for the front, back, left and right panels for heat dissipation.
- The cabinet should be properly grounded.

### 2.2.2 Ventilation

Maintain a minimum clearance of 200mm around the switch for ventilation. After various cables are connected, bundle the cables or place them in the cable management bracket to avoid blocking air inlets. Dust the device every three months to avoid blocking the ventilation openings.

### 2.2.3 Temperature and Humidity

To ensure the normal operation and a prolonged service life of the RG-CS86-20XS4VS2QXS-D switch, maintain an appropriate temperature and humidity in the equipment room. The equipment room with too high or too low temperature and humidity for a long period of time may damage the equipment.

- In an environment with high relative humidity, the insulating material may have bad insulation or even leak electricity. And sometimes the materials may suffer from mechanical performance change and metallic parts may get rusted.
- On the other hand, in an environment with low relative humidity, the insulating strip may dry and shrink, and static electricity may occur easily and endanger the circuit on the device.
- In an environment with high temperature, the equipment is subjected to even greater harm, as its performance may degrade significantly and its service life may be shortened at high temperature for long that expedites the aging process.

Temperature and humidity requirements of the RG-CS86-20XS4VS2QXS-D switch:

Model	Working Temperature	Working Humidity
RG-CS86-20XS4VS2QXS-D	0°C to 50°C (32°F to 113°F)	10% to 90% non-condensing

- i** The temperature and humidity are measured at the point that is 1.5 m above the floor and 0.4 m before the device when there is no protective plate in front or at the back of the device rack.

## 2.2.4 Cleanliness

Dust poses the top threat to the running of the device. The indoor dust falling on the device may be adhered by the static electricity, causing poor contact of the metallic joint. Such electrostatic adherence may occur more easily when the relative humidity is low, not only affecting the service life of the device, but also causing communication faults. The following table shows the requirements for the dust content and granularity in the equipment room.

Substance	Concentration Limit (particles/m <sup>3</sup> )
Dust particles (diameter ≥ 0.5 μm)	≤ 3.5 × 10 <sup>6</sup>
Dust particles (diameter ≥ 5 μm)	≤ 3 × 10 <sup>4</sup>

Apart from dust, the salt, acid and sulfide in the air in the equipment room must also meet strict requirements; as such poisonous substances may accelerate the corrosion of the metal and the aging of some parts. The equipment room should be protected from the intrusion of harmful gases (for example, SO<sub>2</sub>, H<sub>2</sub>S, NO<sub>2</sub> and Cl<sub>2</sub>), whose requirements are listed in the following table.

Gas	Average (mg/m <sup>3</sup> )	Maximum (mg/m <sup>3</sup> )
SO <sub>2</sub>	0.3	1.0
H <sub>2</sub> S	0.1	0.5
NO <sub>2</sub>	0.5	1.0
Cl <sub>2</sub>	0.1	0.3

- i** The **Average** refers to the average limit of harmful gas in one week. The **Maximum** value is the upper limit of the harmful gas in one week, and maximum value can last for up to 30 minutes every day.

## 2.2.5 System Grounding

A good grounding system is the basis for the stable and reliable operation of the RG-CS86-20XS4VS2QXS-D switch. It is the key to prevent lightning stroke and resist interference. Please carefully check the grounding conditions on the installation site according to the grounding requirements, and perform grounding properly as needed.

### Safety Grounding



The device using AC power supply must be grounded by using the yellow/green safety grounding cable. Otherwise, when the insulating resistance decreases between the power supply and the enclosure in the device, electric shock may occur.

**⚠** The building installation shall provide a means for connection to protective earth, and the device is to be connected to that means.

### Lightning Grounding

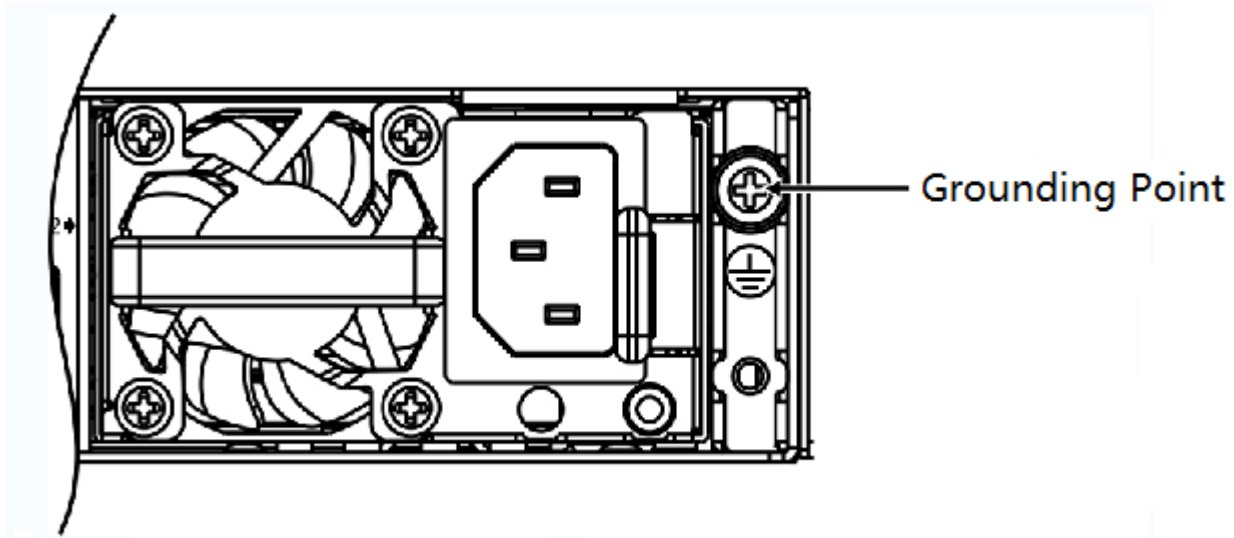
The lightning protection system of the facility is an independent system that consists of the lightning rod, down lead conductor and the connector to the grounding system, which usually shares the power reference ground and yellow/green safety cable ground. The lightning discharge ground is for the facility only, not for the device.

**i** For lightning protection, refer to Appendix C.

### EMC Grounding

The ground required for EMC design includes shielding ground, filter ground, noise and interference suppression, and level reference. All the above constitute the comprehensive grounding requirements. The grounding resistance should be less than  $0.1\Omega$ . There is one grounding pole at the right bottom of the chassis. The grounding poles are pasted with conspicuous warning labels.

Figure 2-1 EMC grounding



### 2.2.6 EMI

Various interference sources, from either outside or inside the device or application system, affect the system in the conductive ways such as capacitive coupling, inductive coupling, and electromagnetic radiation. There are two types of electromagnetic interferences: radiated interference and conducted interference, depending on the type of the propagation path. When the energy, often RF energy, from a component arrives at a sensitive component via the space, the energy is known as radiated interference. The interference source can be either a part of the interfered system or a completely electrically isolated unit. Conducted interference results from the electromagnetic wire or signal cable connection between the source and the sensor. Interference along the cable the interference is transmitted from one unit to another. Conducted interference often affects the power supply of the device, but can be controlled by a filter. Radiated interference may affect any signal path in the device, and is difficult to shield.


- Effective measures should be taken for the power system to prevent electric grid interference.
- The working ground of the routers should be properly separated and kept as far as possible from the grounding device of the power device or the anti-lightning grounding device.
- Keep the device away from high-power radio transmitter, radar transmitting station, and high-frequency large-current device.
- Measures must be taken to isolate static electricity.

## 2.3 Precaution for Fiber Connection

Before connecting the fibers, you should ensure that the type of optical connector and the type of fibers match the type of the optical interface used. Moreover, you should pay attention to the Tx and Rx directions of the fiber. The Tx end of this device should be connected to the Rx end of the peer device, and the Rx end of this device to the Tx end of the peer device.

## 2.4 Installation Tools


Common Tools	Cross screwdrivers, related electric and optical cables, bolts, diagonal pliers, straps
Special-purpose Tools	ESD wrist strap, stripping pliers, crimping pliers, crystal head crimping pliers, wire cutters
Fiber Cleaning Tools	Air-laid paper, fiber end microscope
Meter	Multimeter, errormeter, optic-power meter

 RG-CS86-20XS4VS2QXS-D switch is not shipped with a tool kit. You need to prepare a tool kit by yourself.

## 2.5 Package Contents

### Package Contents

Chassis Carton	Chassis, Yellow/green grounding cables; Quick installation guide; Packing list, Pouched documents
Module Carton	Various modules; Packing list; Quick installation guide

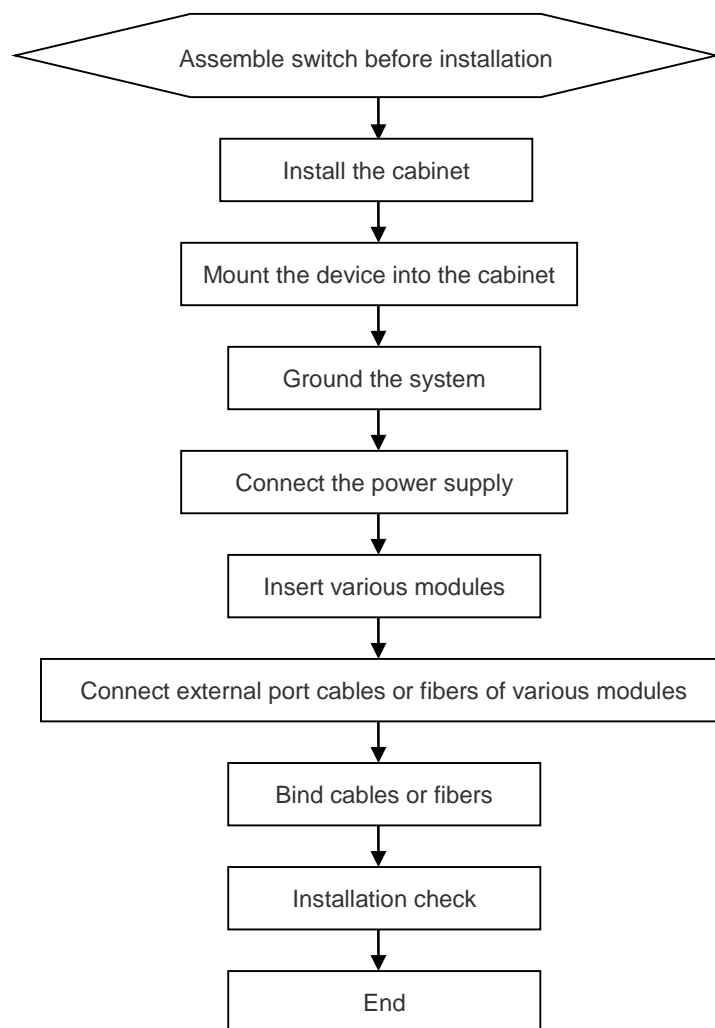
 A normal delivery should contain the above mentioned items, which may differ from the actual delivery, depending on purchase contracts. Please check your goods carefully according to the packing list or purchase contract. If you have any questions or there are any errors, please contact your distributor.

### 3 Product Installation

The RG-CS86-20XS4VS2QXS-D switch must be used and fixed indoors.

- i** Make sure you have carefully read Chapter 2, and be sure that the requirements set forth in Chapter 2 have been met.

#### 3.1 Installation Procedure



#### 3.2 Installation Verification

The RG-CS86-20XS4VS2QXS-D switch is a complicated device. Carefully plan and arrange the installation location, networking mode, power supply, and wiring before installation.

- The installation location provides sufficient space for heat dissipation.
- The installation location meets the temperature and humidity requirements of the device.

- The qualified power supply and current required are available at the installation location.
- The related network cables have already been deployed at the installation location.

### 3.3 Cabinet Installation

#### Precautions

When you install the cabinet, pay attention to the following requirements:

- All expansion bolts for fastening the cabinet base to the ground should be installed and tightened in sequence from bottom up (large plain washer, spring washer, and nut), and the installation holes on the base and the expansion bolts should be well aligned.
- After the cabinet is installed, it should be stable and still.
- After the cabinet is installed, it should be vertical to the ground.
- When multiple cabinets are placed side by side in the room, they should be aligned in a straight line, with an error less than 5 mm.
- The front/back doors of the cabinet should be properly installed. You can open and close them smoothly. The locks should work normally, and all keys should be complete.
- There should be no unnecessary and informal labels inside the cabinet and on various boards.
- Blank panels should be installed completely.
- Fastening screws of various devices in the cabinet of the same model should be ready and tightened.
- Various boards of the device should be installed securely, and the fastening screws on the panel should be tightened.
- All wiring inlets at the top and bottom of the cabinet should be installed with rodent-resistant nets with seams no more than 1.5 cm in diameter, to prevent rodents and other small animals from entering the cabinet.
- Anti-static wrist straps should be provided in the cabinet.

#### Installation Steps

- 1) Plan the available space before installing the cabinet. You must reserve sufficient space for front and back doors for maintenance.
- 2) Mount and fasten the cabinet at the designed location as planned.
- 3) Install the appropriate chute and cables.
- 4) Install the tray and wiring layer on the rack according to the configuration of one rack with one cabinet installed or one rack with multiple cabinets installed.

### 3.4 Mounting into the Cabinet

#### Precautions

Before mounting the RG-CS86-20XS4VS2QXS-D switch into the cabinet, first verify that the front and back brackets of the cabinet are at the right locations. If the bracket is too far forward, the front panel of the device may be too close to the front door, so that the front door cannot be closed when the device is connected with network cables and pigtail fibers. Usually,

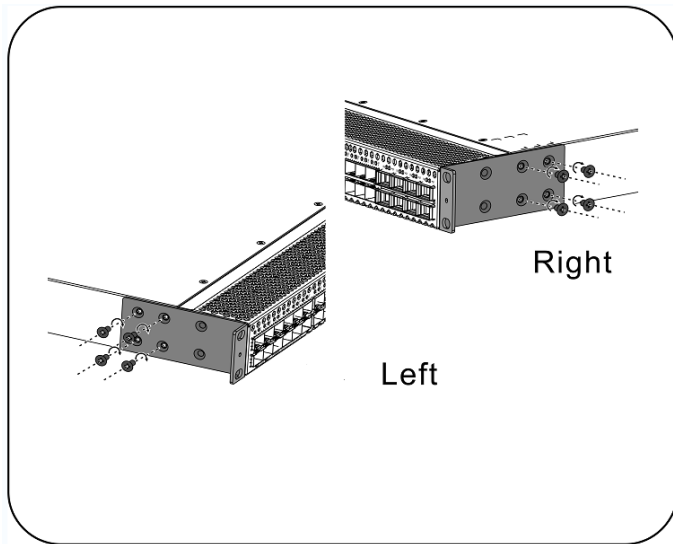
you should reserve space of at least 10mm between the front panel of the device and that of the cabinet after installation. Before mounting into a cabinet, you need to make sure the following conditions are met:

- Fasten the cabinet.
- Insert various modules in the frame properly.
- Remove any obstacle in the frame and the surrounding environment.
- Prepare the device to be installed and move it to the place near the cabinet where you can handle it easily.

### Installing Mounting Brackets

- 1) Take out the two L-shape brackets and eight M4\*8FMO countersink screws from the plastic package.
- 2) Install the brackets at the side panels of the switch, and fix the brackets with four M4\*8FMO countersink screws at each side.

Figure 3-1 Installing Mounting Brackets

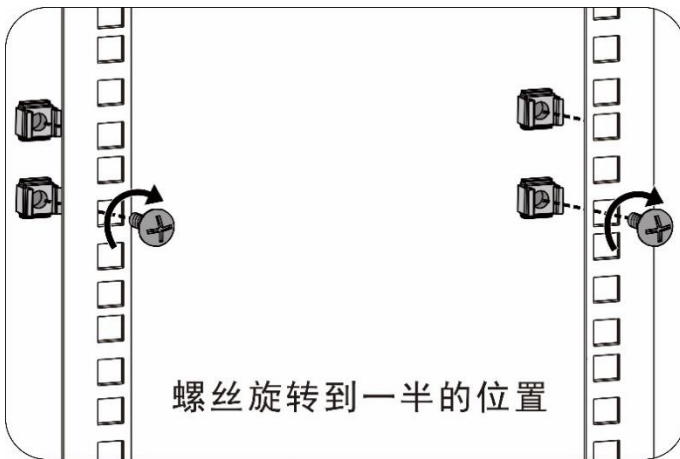


### Mounting the Switch to a Rack

The RG-CS86-20XS4VS2QXS-D switch is qualified for EIA standard and can be installed in 19-inch wiring cabinet. During the process of installation, keep the front panel of the switch forward.

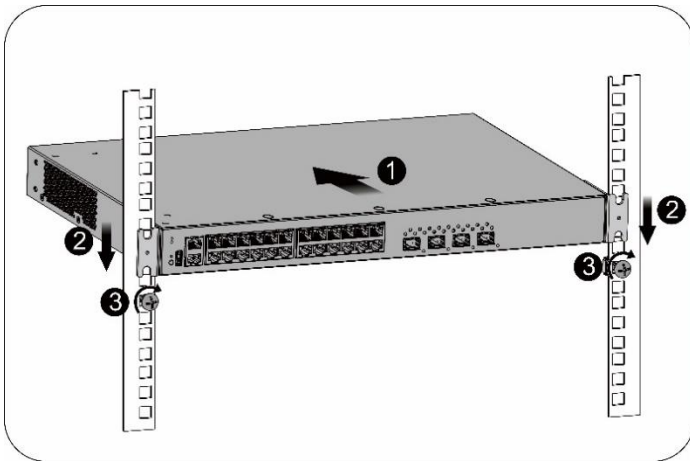
- (1) As shown in Figure 3-2, Install two cage nuts on the inside of each front rack and drive the screws halfway into the cage nuts.

Figure 3-2 Mounting the Switch to a Rack (1)



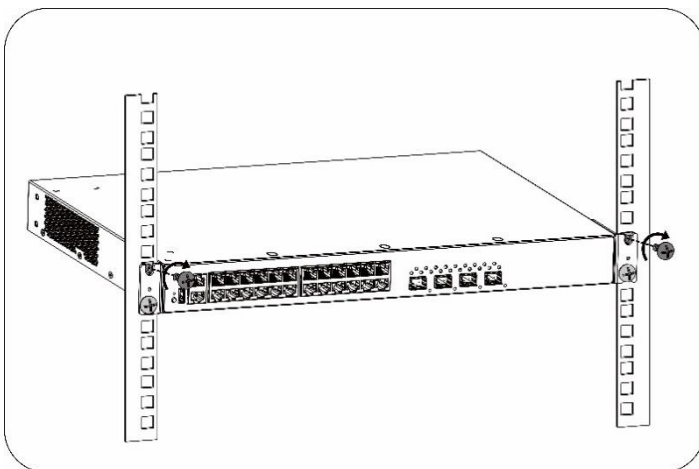
(2) Secure the switch with mounting brackets on the rack rails by tightening the M6 screws.

Figure 3-3 Mounting the Switch to a Rack (2)



(3) Secure the M6 screws.

Figure 3-4 Mounting the Switch to a Rack (3)

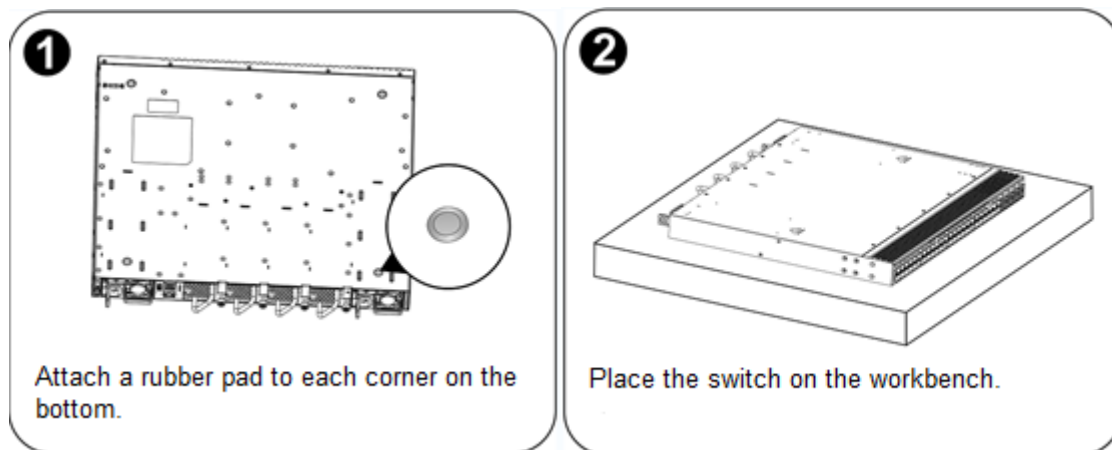


### Mounting the Switch to a Workbench

In some cases, users do not have the 19-inch standard cabinet. The common solution is to place the switch on a clean workbench. The operation is simple as follows:

- 1) Attach the four rubber pads to the four corners on the switch bottom.
- 2) Place the switch on the workbench and ensure good ventilation condition around the switch.

Figure 3-5 Mounting the Switch to a Workbench



## 3.5 Installing and Removing a Fan Module

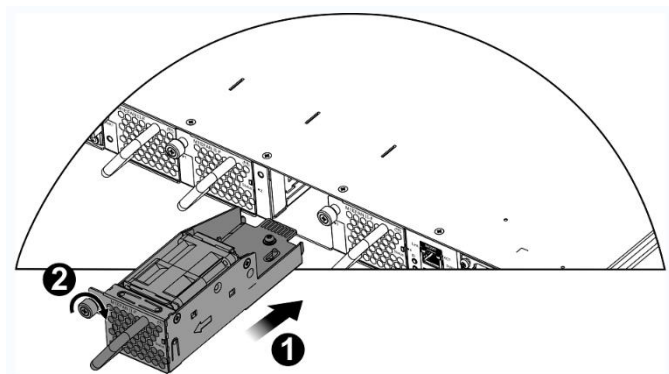
The installation and removal procedures of the M1EFAN II-F are similar to those of the M1SFAN I-F. The M1EFAN II-F is used as an example to introduce its installation and removal procedures.

Wear anti-static gloves before the following operations.

### Installing an Fan Module

- 1) Take out a new fan module from the fan module box.
- 2) Hold the handle at the end of the fan module. Insert the fan module to the chassis slowly along the guide rail until it is fully seated, and make sure that it is in good contact with the slot.
- 3) Tighten the captive screws with a screwdriver to fix the fan module in the switch chassis.

Figure 3-6 Installing a Fan Module



**!** Insert the fan module smoothly. Pay attention to the direction of the fan panel to avoid wrong insertion.

- ⚠ If the position is not proper, withdraw the inserted module and re-insert it.
- ⚠ If the screws cannot be tightened, it is probably because the fan module is not fully inserted. Please check it carefully.
- ⚠ Power modules and fan modules with different air flow direction cannot be used together.

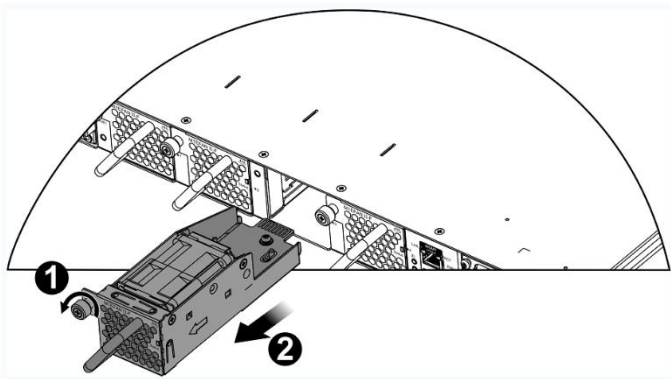
### Removing an Fan Module

Loosen the captive screws of the fan module with a screwdriver.

Hold the handle at the end of the fan module, and withdraw the fan module slowly.

Install the blank panel and put the removed fan module into its package

Figure 3-7 Removing an M1SFAN I-F Fan Module



- ⚠ Withdraw the fan module uprightly and slowly.
- ⚠ Install a blank panel on the location where a fan module is removed to ensure normal ventilation and dissipation and avoid dust in the chassis.

## 3.6 Installing and Removing a Power Module

### 3.6.1 Installing and Removing RG-PA150I-F

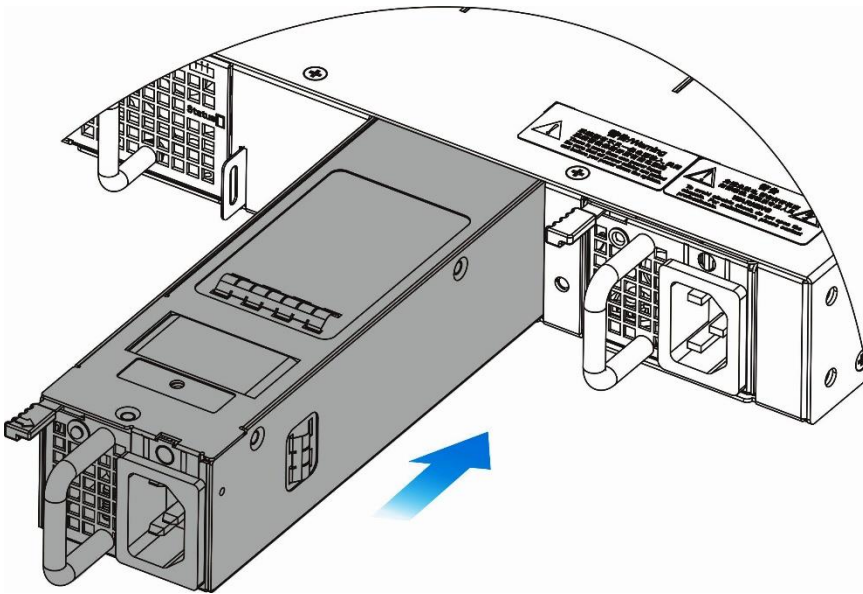
Wear anti-static gloves before the following operations.

#### Installing a RG-PA150I-F Power Module

- 1) Take a new power module out of the package and confirm the input mode and the input parameters of the power module match the requirements.
- 2) Remove the blank panel and take the plane printed with power information as the top panel of the power module. Hold the handle of the power module with one hand, and hold the end of the power module with the other hand. Insert it into the chassis along the guide rail uprightly and slowly until it clicks into place, and make sure that it is in good contact with the power slot.

Figure 3-11 Installing a Power Module



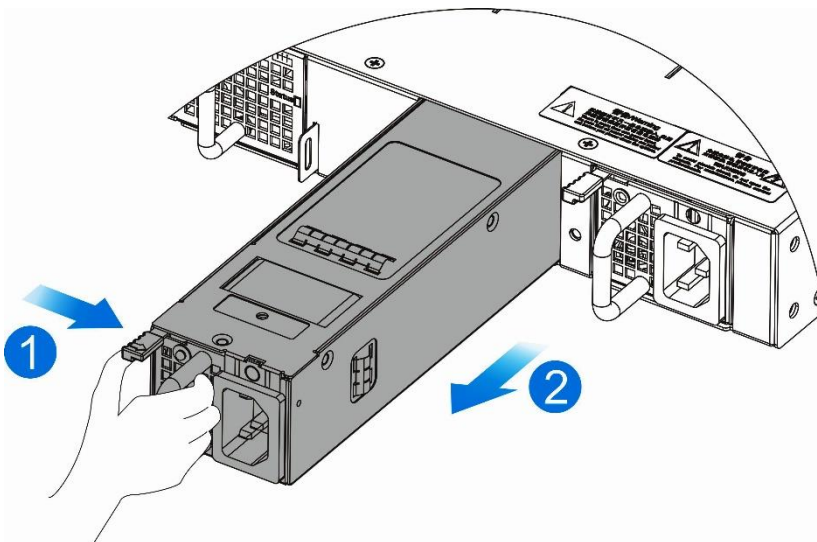


- ⚠ Insert the power module smoothly. Please pay attention to the direction of the power panel to avoid wrong insertion.
- ⚠ If it is difficult or even impossible to insert the module, pull out the module, make sure the power module and guide rail are well aligned, and then insert the module again.

### Removing a RG-PA150I-F Power Module

- 1) Press the plug of the power module, Hold on to the module handle with one hand to pull out part of the module, hold the bottom of it with the other hand, and pull out the power module uprightly and slowly.
- 2) Install a blank panel in the power module slot and put the removed power module into its package.

Figure 3-12 Removing a Power Module



- ⚠ Remove the power module uprightly and slowly.
- ⚠ Install a blank panel in the location where the power module is removed to ensure the normal ventilation and dissipation and avoid the dust in the chassis.

## 3.7 Grounding

A PGND is installed on the back of RG-CS86-20XS4VS2QXS-D switch. First connect the PGND to the grounding terminal of the cabinet and then connect the grounding terminal to the grounding bar of the equipment room.

### Precautions

- The cross sectional area of the grounding cable should be determined according to the possible maximum current. Cables of good conductor should be used.
  - Do not use bare wire.
  - The grounding resistance for combined grounding should be less than 0.1Ω.
- 
- ⚠ To guarantee the security of the person and the device, the RG-CS86-20XS4VS2QXS-D switch must be well-grounded. The grounding resistance should be less than 0.1Ω.
  - ⚠ A service person should check whether or not the socket-outlet from which the device is to be powered provides a reliable connection to the building protective earth. If not, the service person should arrange for the installation of a protective earthing conductor from the separate protective earthing terminal to the protective earth wire in the building.
  - ⚠ The socket-outlet should be installed at a location near the device easy for operation.
  - ⚠ During the device installation, always make the ground connected first and disconnected last.
  - ⚠ The cross-sectional area of protective earthing conductor should be at least 2.5 mm<sup>2</sup> (12 AWG).
- 

## 3.8 Connecting the Cables of the Management Serial Ports

### Simple Connection Steps

Connect the RJ45 connector to the Console interface of the management engine module with shipped console cable , and connect the DB9 connector to the NM or control terminal.

- 
- ⚠ By default, the baud rate is 9600, data bit 8, parity check none, stop bit 1, and flow control none.
- 

## 3.9 Connecting the External Interface Cables

### Precautions

- Correctly distinguish single-mode and multi-mode fibers and ports.
- Avoid bends of small curvature at the connector.

### Simple Connection Steps

1. Connect one end of the RJ45 connector to the Ethernet RCMI interface of the device board, and the other end to the NMS or a control terminal
2. Insert the single-mode or multi-mode fiber into the appropriate interface according to the identification on the panel of the line card. Distinguish the Rx/Tx end of the fiber.
3. Insert the twisted pair with the RJ45 port into the appropriate interface according to the identification on the panel of the line card. Distinguish the crossover cable and straight-through cable.

## 3.10 Binding the Cables

### Precautions

- The power cables and other cables should be bound in a visually pleasing way.
- When you bind fibers, be sure that the fibers at the connectors have natural bends or bends of large curvature.
- Do not bind fibers and twisted pairs too tightly, as this may press the fibers and affect their service life and transmission performance.

### Simple Binding Steps

1. Bind the drooping part of the fibers and twisted pairs of each board, and lead them to both sides of the chassis for convenience.
2. On the both sides of the chassis, fasten the fibers and twisted pairs to the cabinet cable management ring or cabling chute.
3. For the power cables, you should bind them closely along the chassis downward in a straight line wherever possible.

## 3.11 Installation Verification

### Verifying the Cabinet

- Verify if the external power supply matches the distribution panel of the cabinet.
- After device is installed, verify if the front/back cabinet doors can be closed.
- Verify that the cabinet has been fastened completely, and does not move or tilt.
- Verify that the device has been installed in the cabinet, and all the cables have been fastened to the cabinet.
- Maintain a minimum clearance of 200mm around the switch.


### Verifying the Cables

- Verify that the fibers and twisted pairs match the ports.
- Verify that the cables have been bound properly.
- Verify that the cabling specification and connecting method are correct.
- Verify that the cablings are all indoor. If any outdoor cabling is found, check the connection to lightening protection power strip of AC power or lightening arrester of Ethernet port.

### Verifying the Power Supply

- Verify that the power cables are in good contact and comply with the safety requirements.

---

 To avoid body injury and components damage, cut off power supply before checking the installation.

---

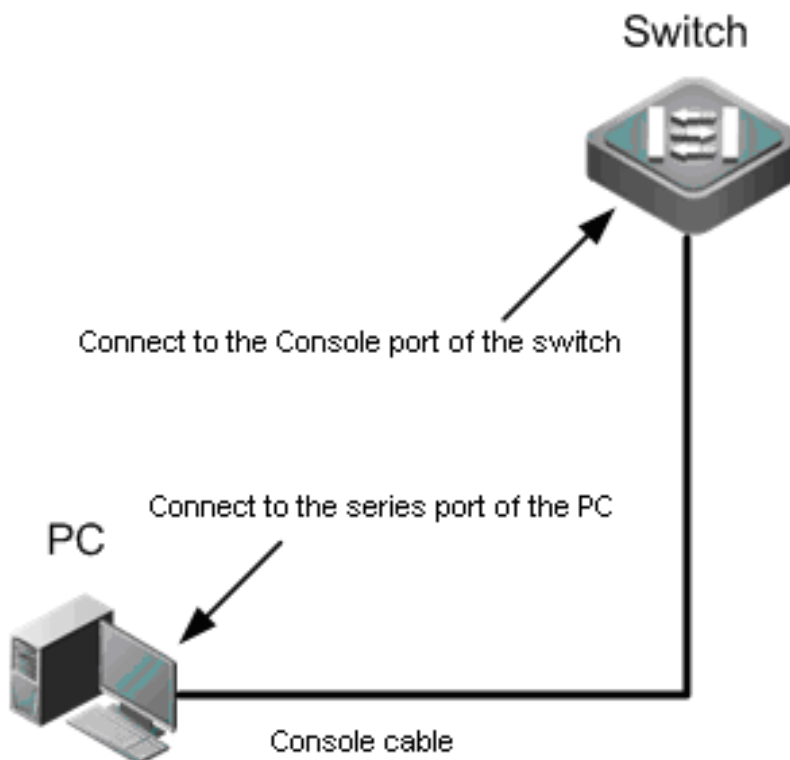
## 4 System Debugging

### 4.1 Establishing the Configuration Environment

#### Establishing the Configuration Environment

Connect the PC to the console port of the switch through the console cable, as shown in Figure 4-1.

Figure 4-1 Configuration Environment



#### Connecting the Console Cable

- 1) Connect one end of the DB-9 jack of the console cable to the serial port of the PC.
- 2) Connect one end of the console cable RJ45 to the console port of the switch.

#### Setting Terminal Parameters

- Step One: Start the PC and run the terminal simulation program on the PC, such as Terminal on Windows 3.1 or HyperTerminal on Windows 95/98/NT/2000/XP.
- Step Two: Set terminal parameters. The parameters are as follows: baud rate 9600, data bit 8, parity check none, stop bit 1, and flow control none. Details are as follows:

Choose Start > Programs > Accessories > Communications > Hyperterminal.

Choose Cancel. The Connection Description window appears as shown in Figure 4-2.

Figure 4-2



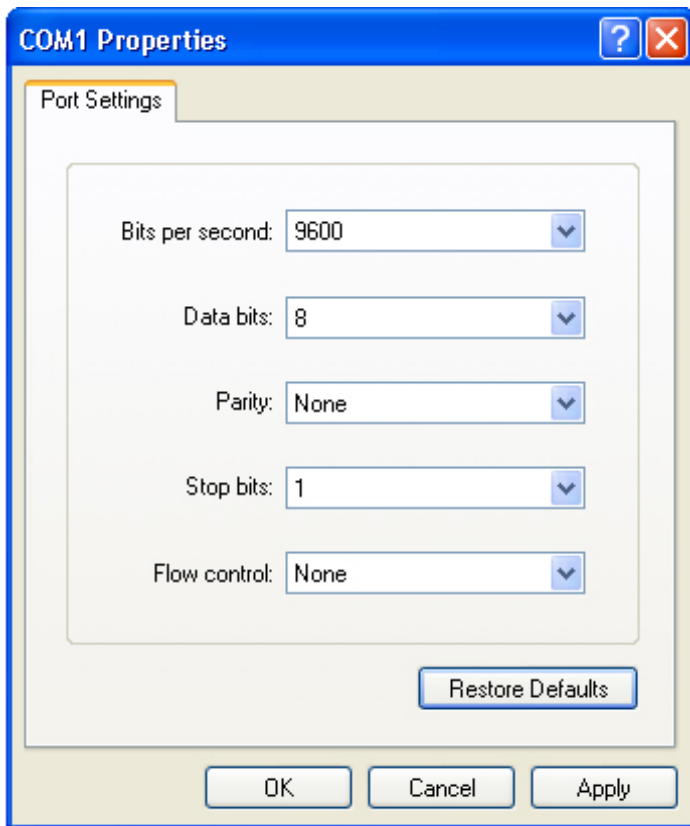
Enter the name of the new connection and click **OK**. A window appears as shown in Figure 4-3. In the column of Connect Using field, select the serial port you want to use.

Figure 4-3



After the serial port is selected, click **OK**. The Serial Port Parameter Setting window is displayed, as shown in Figure 4-4. Set the baud rate as 9600, data bit as 8, parity check as none, stop bit as 1, and flow control as none.

Figure 4-4



After the serial port parameters are set, click **OK** to enter hyper terminal window.

## 4.2 Power-on Startup

### Checking before Power-on

- Check if the switch is fully grounded.
- Check if the fan module and the power module are correctly installed.
- Check if the power cable is correctly connected.
- Check if the power supply voltage complies with the requirement of the switch.
- Check if the console cable is correctly connected; the terminal (can be a PC) used for configuration is already started and the parameters are already configured.

### Checking After Power-on (Recommended)

After power-on, you are recommended to perform the following checks to ensure the normal operation of follow-up configurations.

- Check if printed information appears on the terminal interface.
- Check if the device indicator is normal.

## 5 Monitoring and Maintenance

### 5.1 Monitoring

#### Indicator

When the RG-CS86-20XS4VS2QXS-D switch is running, users can monitor the status of host and each module by inspecting corresponding indicators.

- When the indicator of the master CM is red, it means the system has a fault, in which case you can determine and eliminate the fault by viewing with the management software.
- When the indicator of the master CM is yellow, it means the system temperature exceeds the alarm temperature, affecting the system operation performance. However, the system can continue running. In this case, you can determine and eliminate the fault by viewing with the management software.
- When the indicator of the fan module is red, it means that a fan tray is faulty and the system can continue running, in which case you can determine and eliminate the fault by viewing with the management software.
- When the indicator of the host or the expansion module is red or flashing, it indicates a failure, in which case you need to find out the cause, and turn off the power when necessary.
- When the RWR1/PWR2 indicator of the device is red, it means that the power supply is faulty, in which case you should replace it promptly.

#### CLI Commands

The RG-CS86-20XS4VS2QXS-D switch allows you to monitor various system statuses by executing the appropriate CLI commands, including:

- Working status of host
- Configuration information and status of port
- Working status of fan and power supply
- Temperature status

---

 For the monitoring commands, refer to *Ruijie RG-CS86-20XS4VS2QXS-D Switches RGOS Configuration Guide*.

---

### 5.2 Hardware Maintenance

#### Expansion Module Maintenance

To replace a board, do replacement according to the instructions provided in Sections of Installing Modules and Removing Modules.

#### Ventilation System Maintenance

- The fan is provided with the fault monitoring signals. When the fan fails, a corresponding alarm will be generated.
- Replace the faulty fan with a qualified one.

- Tighten the captive screws of the fan module.

### **Power Supply Maintenance**

When the power supply fails, you only need to disconnect the power cable, unplug the power module, replace it with a qualified one, and then connect the power cables.

### **Replacing Lithium Battery**

The built-in lithium batteries can support the real time clock of the RG-CS86-20XS4VS2QXS-D switch without external power supply.

Please contact Ruijie technical support for replacing lithium batteries.

- 
- ❗ Replacing the battery with the incorrect model may cause explosion or danger. If the battery is damaged, replace it with the same model.
  - ❗ Exposing the battery to extremely high temperatures and/or extremely low air pressure may cause the battery to explode or leak flammable liquids or gases.
  - ❗ Throwing the battery into a fire or oven, or mechanically crushing or cutting it may cause the battery to explode.
- 

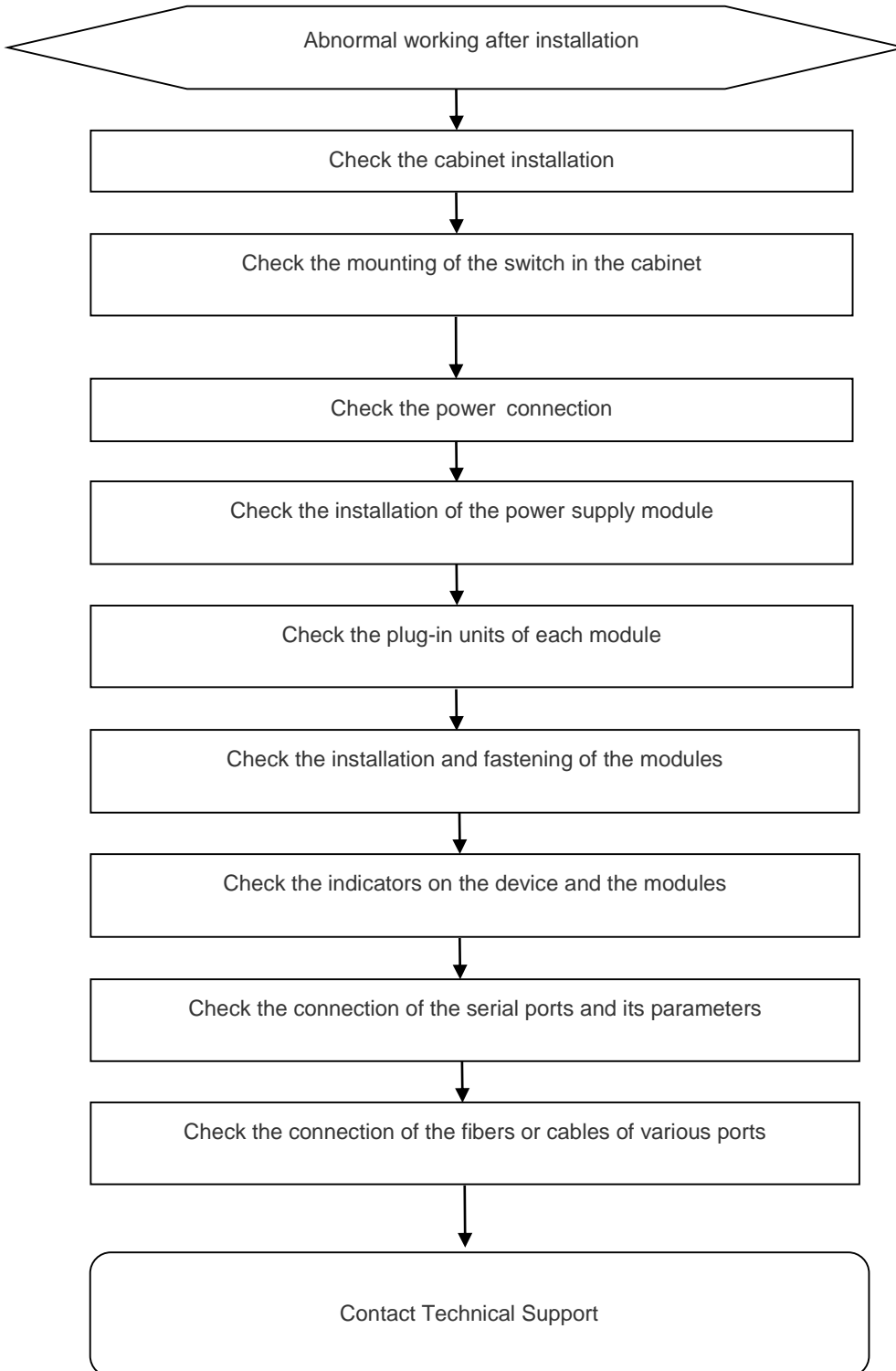
### **Replacing Fuses**

Please contact Ruijie technical support for replacing fuses.



## 6 Troubleshooting

### 6.1 General Troubleshooting Procedures



## 6.2 Common Issues

### Fault 1: The system login password is forgotten

[Fault Description]

The system login password of the switch is forgotten, and so it is not possible to configure the data.

[Troubleshooting]

Please contact Ruijie Customer Service Department for technical support.

### Fault 2: The AC power module does not work

The indicator on the front panel of host is OFF. The Status indicator of fan module is OFF, ,and the fan does not work.

The indicator on the panel of the power module is OFF. The fan does not work.

[Troubleshooting]

First disconnect the power cord of the power module . Check if the cables of the cabinet have been correctly connected. Check whether the cabinet power sockets are loosely connected to power modules. Check whether the power modules are installed correctly. If necessary, pull out the power modules and check whether the connectors of the power system get loose.

### Fault 3: The fan does not work.

[Fault Description]

After the system starts, the fans in the fan module do not work or the Status indicator is OFF.

[Troubleshooting]

Check if the connection between the fan module and the backplane is secure and if the connector gets loose. If the connection is secure, you need to replace the fan disk.

### Fault 4: The serial port console has no output.

[Fault Description]

After the system is started, the serial console does not display any information.

[Troubleshooting]

Check whether serial port cables are connected correctly, whether serial port cables are disconnected, and whether the connected serial port is identical with that configured on the hyper terminal. Check whether the configuration of the serial port on the hyper terminal is the same as that described in *Ruijie RG-CS86-20XS4VS2QXS-D Switches RGOS Configuration Guide*. If not, modify the serial port configuration parameters. If there is still no serial port printed information, please contact Ruijie Customer Service Department for technical support.

### Fault 5: The serial port console outputs illegible characters.

[Fault Description]

The serial port console outputs illegible characters, which are unable to identify.

[Troubleshooting]

Such a problem is related to the settings of the serial port. Check if the settings of such parameters as the baud rate match those in *Ruijie RG-CS86-20XS4VS2QXS-D Switches RGOS Configuration Guide*.

**Fault 6: The newly-inserted service card module fails to be powered on.**

[Fault Description]

The system is running, yet all indicators on the panel of the newly-inserted expansion module are OFF, and the port is faulty.

[Troubleshooting]

Check whether the module is inserted correctly. If the newly-inserted module still cannot be powered on even though the checking is ok, please contact Ruijie technical support.

**Fault 7: The link cannot be set up between fiber interfaces**

[Fault Description]

The system runs normally. After the fiber interface is inserted into the optical module and the optical fiber is properly connected, the link cannot be set up.

[Troubleshooting]

- 1) Check whether the receiving and sending ends are wrongly connected. The sending end of the fiber interface needs to be connected to the receiving end of the other fiber interface. You can check by changing the sequence in which the two optical fibers are connected on the optical module.
- 2) Check whether the optical module wavelengths of the two sides are consistent. For example, an optical module of 1310nm wavelength cannot be connected to an optical module of 1550nm wavelength.
- 3) Check whether the distance between the two sides exceeds the length indicated on the optical module.
- 4) Check whether the rates of the two sides match and whether the optical fiber type meets requirements. In addition, for ports supporting different rates. Check whether rate modes are configured correctly.

## Appendix A Connectors and Connection Media

### 10GBASE-T/5GBASE-T/2.5GBASE-T/1000BASE-T/100BASE-TX Port

10GBASE-T/5GBASE-T/2.5GBASE-T/1000BASE-T/100BASE-TX is a port that supports self-adaptation of five rates, and automatic MDI/MDIX Crossover at these three rates.

#### 10GBASE-T

10GBASE-T complies with IEEE 802.3an standard, and the supported cables and cabling distances are listed in the following table. 10GBASE-T port uses four pairs of wires for transmission, all of which must be connected. The following table shows the connection of the twisted pairs used by the 10GBASE-T port.

Cable	CAT7 STP	CAT6A STP	CAT6A UTP	CAT6 STP	CAT6 UTP
Description	Cat-7 shielded twist pairs	Cat-6A shielded twist pairs	Cat-6A unshielded twist pairs	Cat-6 shielded twist pairs	Cat-6 unshielded twist pairs
Model	Class F ISO/IEC 11801	Class Ea ISO/IEC 11801 Ed2.1/TIA-568-C.2		Class E ISO/IEC TR24750 TSB-155	
Max Transmission Distance	100 m	100 m		100 m	37 m to 55 m
Cabling System Bandwidth	600 MHz	500 MHz		250 MHz	
Description	Meet the minimum performance requirements of 10Gbase-T standard.			Strictly follow TSB-155 standard requirements to ensure the reliable application of 10Gbase-T.	

- i** The maximum transmission distance will be less than 37m when CAT6 UTP unshielded wire is exposed in severe condition and influenced by external crosstalk..
- i** It is recommended to use CAT6A shielded wire or wires with higher specifications for the cabling of the new equipment room. CAT6A or CAT7 shielded wire can maximize the avoidance of external crosstalks. Note the cabling system and the overall grounding when shielded wire is used.
- i** CAT6A unshielded wire or CAT6 wire is applied in the cabling of the equipment room. The cabling must meet TSB-155 requirements. And the recommended cabling rules are as follows:
  - 1) Avoid mixed cabling with other cables, or use metal clapboard in the trunking to isolate different wires.
  - 2) At the outlet end of the device, place the wire separately and ensure parallel cabling. Most of the crosstalks happen within the 20 m started from the outlet end of the device, so it is suggested not to bind up the wires within the first 5 m-20 m.
  - 3) Bind CAT6A unshielded wire every 50cm-70cm when the wires need to be bound. Bind CAT6 unshielded wire every 160cm-180cm as loosely as possible.
  - 4) The suggested number of wires in a bundle is not more than 12.
  - 5) CAT6 wire connector is replaced with CAT6A wire connector.

#### 5GBASE-T

Compliant with IEEE 802.3bz, 5GBASE-T requires 100-ohm CAT6 UTP or STP (recommended) with a maximum distance of 100 meters (328 feet).

- i** The CAT6 UTP wire must meet TIA TSB-5021 requirements. And the recommended cabling rules are as follows:
  - 1) Avoid mixed cabling with other cables, or use metal clapboard in the trunking to isolate different wires.
  - 2) The CAT6 UTP wires shorter than 20 meters meet the minimum requirement of 5GBASE-T.
  - 3) At the outlet end of the device, place the wire separately and ensure parallel cabling. Most of the crosstalks happen within the 25 m started from the outlet end of the device, so it is suggested not to bind up the wires within the first 25 m.
  - 4) Bind CAT6 unshielded wire every 160cm-180cm as loosely as possible.
  - 5) The suggested number of wires in a bundle is not more than 7.
  - 6) CAT6 wire connector is replaced with CAT6A wire connector.

### 2.5GBASE-T

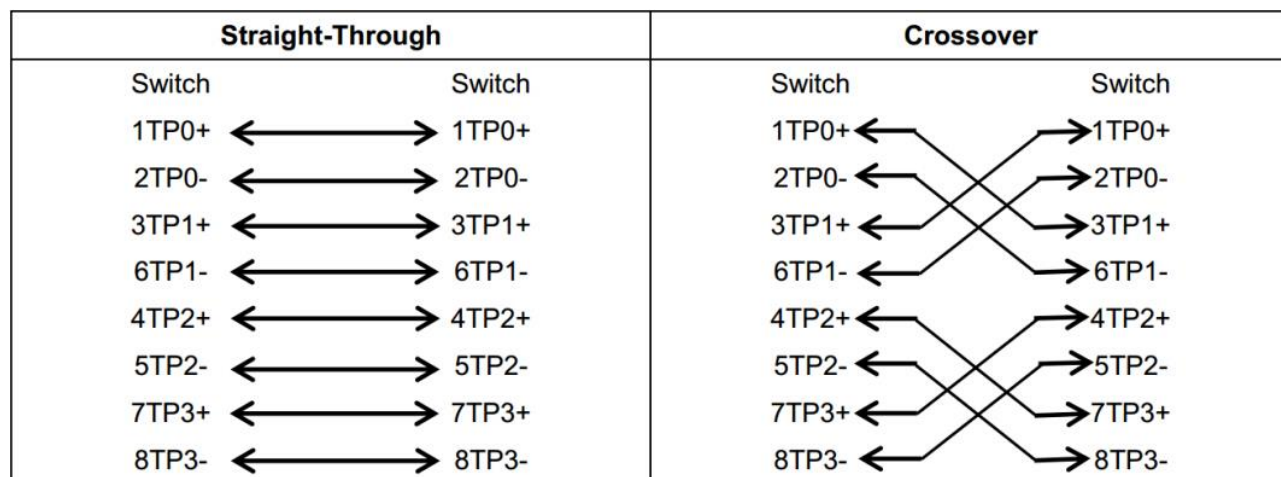
Compliant with IEEE 802.3bz, 2.5GBASE-T requires 100-ohm CAT5e UTP or STP (recommended) with a maximum distance of 100 meters.

- i** The maximum transmission distance will be less than 50m when CAT5e UTP unshielded wire is exposed in severe condition and influenced by external crosstalk.
- i** The CAT5e UTP wire must meet TIA TSB-5021 requirements. And the recommended cabling rules are as follows:
  - 1) Avoid mixed cabling with other cables, or use metal clapboard in the trunking to isolate different wires.
  - 2) The CAT5e UTP wires shorter than 50 meters meet the minimum requirement of 2.5GBASE-T.
  - 3) At the outlet end of the device, place the wire separately and ensure parallel cabling. Most of the crosstalks happen within the 25 m started from the outlet end of the device, so it is suggested not to bind up the wires within the first 5-25 m.
  - 4) Bind CAT6 unshielded wire every 120cm-180cm as loosely as possible.
  - 5) The suggested number of wires in a bundle is not more than 7.
  - 6) CAT6 wire connector is replaced with CAT6A wire connector.

### 1000BASE-T

The 1000BASE-T complies with IEEE 802.3ab standard, and uses up to 100m of 100-ohm CAT5, CAT5E or twisted pairs with higher standard. The 1000BASE-T port uses four pairs of wires for transmission, all of which must be connected. Figure A-1 shows the connection of the twisted pairs used by the 1000BASE-T port:

Figure A-1 Four twisted pairs of the 1000BASE-T



### 100BASE-TX

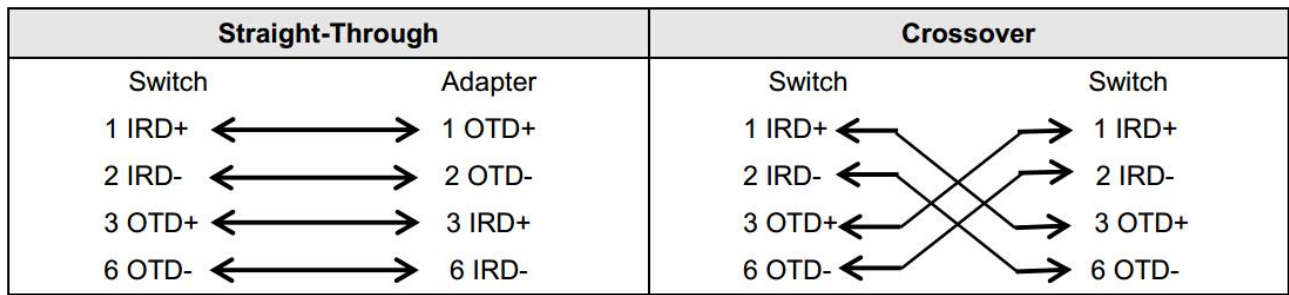
In addition to the above cables, the 100BASE-TX can use up to 100m of 100-ohm CAT5. Figure A-2 shows the definition of pin signal concerning the 100BASE-TX:

Figure A-2 Definition of pin signal concerning the 100BASE-TX

Pin	Socket	Plug
1	Input Receive Data+	Output Transmit Data+
2	Input Receive Data-	Output Transmit Data-
3	Output Transmit Data+	Input Receive Data+
6	Output Transmit Data-	Input Receive Data-
4, 5, 7, 8	Not Used	Not Used

Figure A-3 shows the feasible connections of the straight-through and crossover twisted pairs of the 100BASE-TX.

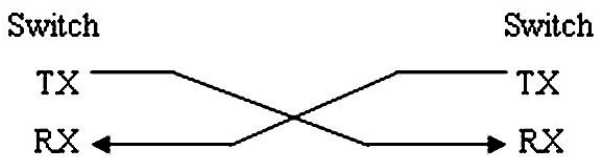
Figure A-3 Connection of the twisted pairs of the 100BASE-TX/10BASE-T



### Fiber Connection

For the fiber ports, select single-mode or multiple-mode fibers for connection according to the fiber module connected. The connection schematic diagram is shown in Figure A-4:

Figure A-4 Schematic Diagram for Fiber Connection



## Appendix B Mini-GBIC, 2.5G, 10G, 25G, 40G and 100G Module

We provide 1000M SFP modules (Mini-GBIC modules), 2.5G SFP modules, 10G SFP+ modules, 40G QSFP+ modules and 100G modules. according to the types of interfaces of the switch modules. You can select modules to suit your specific needs. The following models and technical specifications of some 1000M SFP modules, 2.5G SFP modules, 10G SFP+ modules, 40G QSFP+ modules and 100G modules are listed for your reference. For detailed specifications, please refer to *Mini-GBIC, SFP Series Modules Specifications, 10G SFP+ Series Modules Specifications* and *40G QSFP+ Series Modules Specifications*.

### Models and Technical Specifications of the Mini-GBIC (SFP) Module

GBIC/SFP	Wavelength (nm)	Optical Fiber Type	DDM Supported (Yes/No)	Intensity of Transmitted Light (dBm)		Intensity of Received Light (dBm)	
				min	max	min	max
MINI-GBIC-SX-MM850	850	MMF	No	-9.5	-3	-17	0
MINI-GBIC-LX-SM1310	1310	SMF	No	-9.5	-3	-20	-3
GE-eSFP-SX-MM850	850	MMF	Yes	-9.5	-3	-17	0
GE-eSFP-LX-SM1310	1310	SMF	Yes	-9.5	-3	-20	-3
MINI-GBIC-LH40-SM1310	1310	SMF	Yes	-2	3	-22	-3
MINI-GBIC-ZX50-SM1550	1550	SMF	Yes	-5	0	-22	-3
MINI-GBIC-ZX80-SM1550	1550	SMF	Yes	0	4.7	-22	-3
MINI-GBIC-ZX100-SM1550	1550	SMF	Yes	0	5	-30	-9
GE-SFP-LX20-SM1310-BIDI	1310TX/1550RX	SMF	Yes	-9	-3	-20	-3
GE-SFP-LX20-SM1550-BIDI	1550TX/1310RX	SMF	Yes	-9	-3	-20	-3
GE-SFP-LH40-SM1310-BIDI	1310TX/1550RX	SMF	Yes	-5	0	-24	-1
GE-SFP-LH40-SM1550-BIDI	1550TX/1310RX	SMF	Yes	-5	0	-24	-1
SFP-S4-R1000P1 V1	1310	SMF	No	-9.5	-3	-20	-3

### Cabling Specifications

GBIC/SFP	Wavelength (nm)	Media Type	Core Size (μm)	Maximum Cabling Distance
MINI-GBIC-SX-MM850	850	MMF	62.5/125	275m
			50/125	550m
MINI-GBIC-LX-SM1310	1310	SMF	9/125	10km
GE-eSFP-SX-MM850	850	MMF	62.5/125	275m
			50/125	550m
GE-eSFP-LX-SM1310	1310	SMF	9/125	10km
MINI-GBIC-LH40-SM1310	1310	SMF	9/125	40km

MINI-GBIC-ZX50-SM1550	1550	SMF	9/125	50km
MINI-GBIC-ZX80-SM1550				80km
MINI-GBIC-ZX100-SM1550				100km
GE-SFP-LX20-SM1310-BIDI	LC	SMF	9/125	20km
GE-SFP-LX20-SM1550-BIDI	LC	SMF	9/125	20km
GE-SFP-LH40-SM1310-BIDI	LC	SMF	9/125	40km
GE-SFP-LH40-SM1550-BIDI	LC	SMF	9/125	40km
SFP-S4-R1000P1 V1	1310	SMF	9/125	10km

### SFP BIDI Modules

Rate/Distance	Model
Gigabit/20km	GE-SFP-LX20-SM1310-BIDI GE-SFP-LX20-SM1550-BIDI
Gigabit/40km	GE-SFP-LH40-SM1310-BIDI GE-SFP-LH40-SM1550-BIDI

 BIDI modules must be used in pairs. If one end uses GE-SFP-LX20-SM1310-BIDI, the other end must use GE-SFP-LX20-SM1550-BIDI.

### Models and Technical Specifications of the Mini-GBIC-GT Module

Model

Standard	1000Base-T SFP Module
1000Base-T	Mini-GBIC-GT

1000Base-T Cabling Distance

1000baseT	Copper Cable Type	Cabling Distance	DDM Supported (Yes/No)
Mini-GBIC-GT	CAT5, CAT6, CAT7	100m	No

### Models and Technical Specifications of the 2.5G SFP Module

SFP	Wavelength (nm)	Optical Fiber Type	DDM Supported (Yes/No)	Intensity of Transmitted Light (dBm)		Intensity of Received Light (dBm)	
				min	max	min	max
2.5G-SFP-LX03-SM1310-BIDI-I	1310TX/1550RX	SMF	Yes	-9	-3	-16	-3
2.5G-SFP-LX03-SM1550-BIDI-I	1550TX/1310RX	SMF	Yes	-9	-3	-16	-3

### Cabling Specifications of the 2.5G SFP Module

Model	Interface Type	Optical Fiber Type	Core Size (μm)	Modular Bandwidth (MHz·km)	Maximum Cabling Distance
-------	----------------	--------------------	----------------	----------------------------	--------------------------



2.5G-SFP-LX03-SM1310-BIDI-I	LC	SMF	9/125	N/A	3 km
2.5G-SFP-LX03-SM1550-BIDI-I	LC	MMF	9/125	N/A	3 km

### Models and Technical Specifications of the 10G SFP+ Module

The existing 10G SFP+ optical modules:

Model	Wave length (nm)	Optical Fiber Type	Core Size (μm)	Modular Bandwidth (MHz·km)	Max Cabling distance	Intensity of Transmitted Light (dbm)		Intensity of Received Light (dbm)	
						min	max	min	max
XG-SFP-SR-MM850	850	MMF (LC interface)	62.5	200	33m	-5	-1	-7.5	0.5
				160	26m				
			50	2000	300m				
				500	82m				
			400	66m					
XG-SFP-LR-SM1310	1310	SMF (LC interface)	9	N/A	10km	-8.2	0.5	-10.3	0.5
XG-SFP-ER-SM1550	1550	SMF (LC interface)	9	N/A	40km	-4.7	4	-11.3	-1
XG-SFP-ZR-SM1550	1550	SMF (LC interface)	9	N/A	80km	0	4	-24	-7
SFP-M3-R1000P1	850	SMF (LC interface)	62.5	200	33m	-5	-1	-7.5	0.5
				160	26m				
			50	2000	300m				
				500	82m				
			400	66m					
SFP-S1-R1000P1	1310	SMF (LC interface)	9	N/A	10km	-8.2	0.5	-10.3	0.5
SFP-S4-R1000P1 V2	1310	SMF (LC interface)	9	N/A	10km	-8.2	0.5	-10.3	0.5

The existing 10G SFP+ copper modules:

Model	Module Type	Connector Type	Copper Cable Length(m)	Conductor Wire Diameter (AWG)	Data Rate(Gb/s)	DDM Supported (Yes/No)
XG-SFP-CU1M	Passive	SFP+	1	28	10.3125	No
XG-SFP-CU3M	Passive	SFP+	3	28	10.3125	No

XG-SFP-CU5M	Passive	SFP+	5	26	10.3125	No
-------------	---------	------	---	----	---------	----

### Models and Technical Specifications of the 25G SFP28 Module

Model	Wave length (nm)	Optical Fiber Type	Core Size (μm)	Modular Bandwidth (MHz·km)	Max Cabling distance	Intensity of Transmitted Light (dbm)		Intensity of Received Light (dbm)	
						min	max	min	max
VG-SFP-SR-MM850	850	MMF	50	4700	100m	-8.4	2.4	-10.3	2.4
VG-SFP-LR-SM1310	1310	SMF	9	NA	10KM	-4.5	3	-11.4	2

**i** 25G SFP28 ports working in 25G support SFP modules and do not support DAC cables.

### Models and Technical Specifications of the 40G QSFP+ Module

Model	Wave length (nm)	Optical Fiber Type	Core Size (μm)	Modular Bandwidth (MHz·km)	Max Cabling distance	DDM Supported (Yes/No)	Intensity of Transmitted Light (dbm)	Intensity of Received Light (dbm)
40G-QSFP-SR-MM850	850	MMF (MPO interface)	50	2000	100m (OM3)	Yes	-7.6 to 2.4 (Perlane)	-9.5 to 2.4 (Perlane)
			50	4700	150m (OM4)			
40G-QSFP-LSR-MM850	850	MMF (MPO interface)	50	2000	300m (OM3)	Yes	-7.6 to 2.3 (Perlane)	-9.9 to 2.4 (Perlane)
			50	4700	400m (OM4)			
40G-QSFP-LR4-SM1310	1310	LC	9	N/A	10km	Yes	-7.0 to 2.3 (Perlane)	-13.7 to 2.3 (Perlane)

The existing 40G QSFP+ copper modules:

Model	Module Type	Connector Type	Copper Cable Length (m)	Conductor Wire Diameter (AWG)	Data Rate(Gb/s)	Support DDM (Yes/No)
40G-QSFP-STACK1M	Passive	QSFP+	1	28	4lanes x 10.3125	No
40G-QSFP-STACK3M	Passive	QSFP+	3	28	4lanes x 10.3125	No

### Models and Technical Specifications of the 100G QSFP28 Module

Model	Wavelength (nm)	Fiber Type	Core Size (μm)	Modular Bandwidth (MHz·km)	Max Cabling distance	Intensity of Transmitted Light (dbm)		Intensity of Received Light (dbm)		DDM Supported (Yes/No)
						min	max	min	max	
	850	MMF	50	2000	70m (OM3)	-8.4	2.4	-10.3	2.4	Yes

---

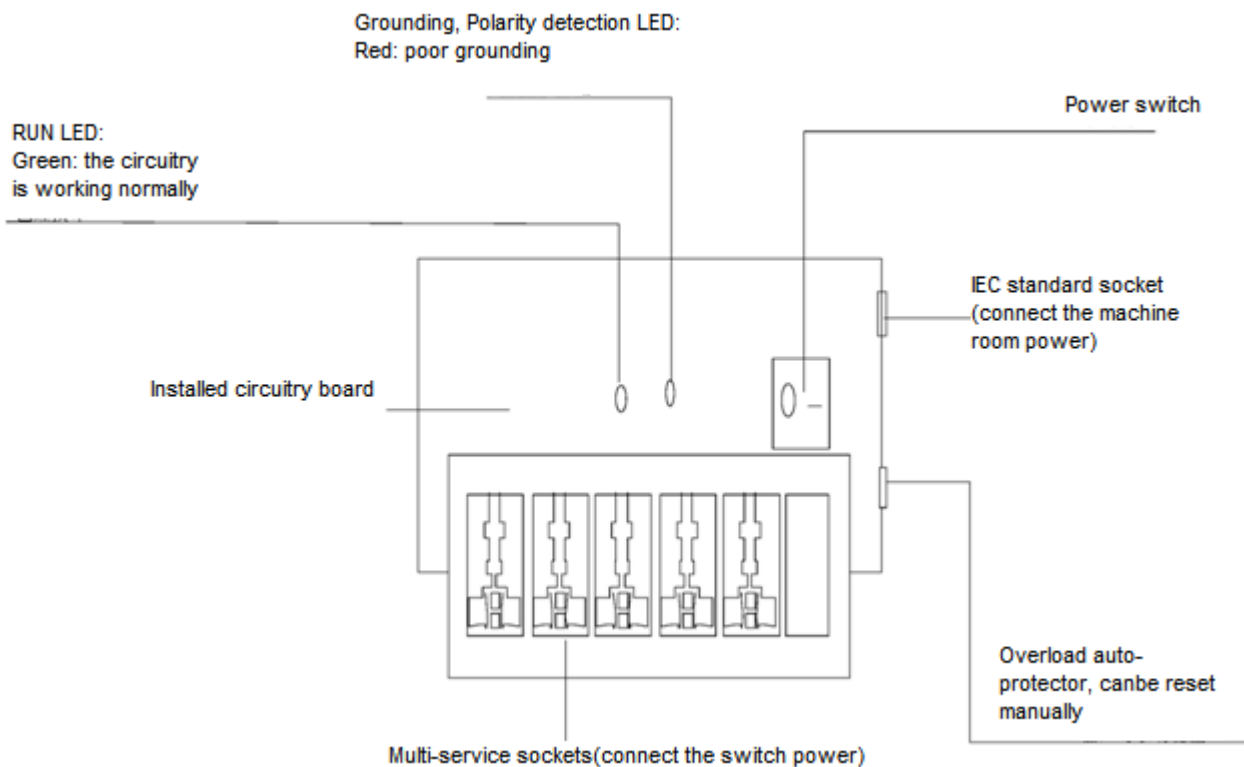
100GBASE-SR4 QSFP28		(MPO interface)	50	4700	100m (OM4)					
100GBASE-LR4 QSFP28	1301	LC interface	9	N/A	10km	-4.3	4.5	-10.6	4.5	Yes

## Appendix C Lightning Protection

### Installing AC Power Arrester (lightning protection cable row)

The external lightning protection cable row should be used on the AC power port to prevent the switch from being struck by lightning when the AC power cable is introduced from the outdoor and directly connected to the power port of the switch. The lightning protection cable row is fixed on the cabinet, operating table or the wall in the machine room using the line buttons and screws. AC enters the lightning protection cable row and then gets to the switch.

Figure C-1 Schematic Diagram for the Power Arrester



**i** The power arrester is not provided and the user should purchase it to address the practical requirement.

Precautions for installation:

- Make sure that the PE terminal of the power arrester has been well-grounded.
- After the switch AC power plug is connected to the socket of the power arrester (lightning protection cable row), lightning protection function implements if the RUN indicator is green and the ALARM indicator is off.
- If the ALARM indicator on the power arrester is Red, you should check whether it is caused by poor grounding connection or by the reversed connection of the Null and Live lines: Use the multimeter to check the polarity of the power socket for the arrester when the indicator is red, if the N line is on the left and the L line is on the right (facing the socket), the arrester PE terminal is not grounded; if the L line is on the left and the N line is on the right, the polarity of the arrester power cable shall be reversed by the power arrester; if the indicator is still red, it is confirmed that the arrester PE terminal has not been grounded.

## Installing the Ethernet Port Arrester

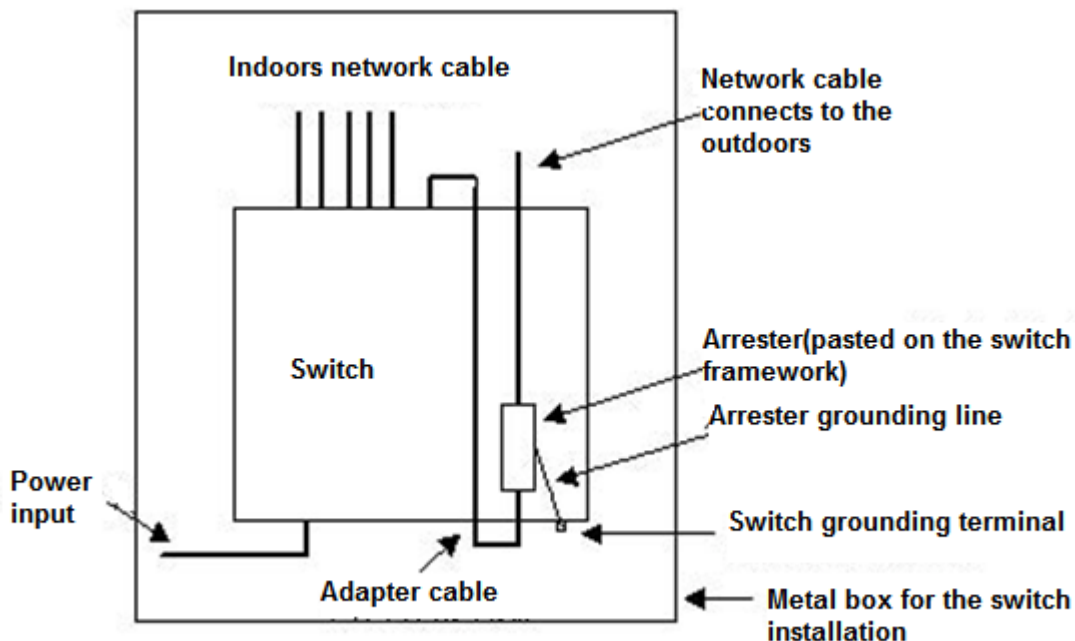
During the switch usage, the Ethernet port arrester should be connected to the switch to prevent the switch damage by lightning before the outdoor network cable connects to the switch .

Tools: Cross or straight screwdriver, Multimeter, Diagonal pliers

Installation Steps:

- 1) Tear one side of the protection paper for the double-sided adhesive tape and paste the tape to the framework of the Ethernet port arrester. Tear the other side of the protection paper for the double-sided adhesive tape and paste the Ethernet port arrester to the switch framework. The paste location for the Ethernet port arrester should be as close to the grounding terminal of the switch as possible.
- 2) Based on the distance of the switch grounding terminal, cut the grounding line for the Ethernet port arrester and firmly tighten the grounding line to the grounding terminal of the switch.
- 3) Use the multimeter to check whether the grounding line for the arrester is in good contact with the switch grounding terminal and the framework.
- 4) According to the description on the Ethernet Port Arrester Hardware Installation Guide, connect the arrester using the adapter cable(note that the external network cable is connected to the end of IN, while the adapter cable connected to the switch is connected to the end of OUT) and observe whether the indicator on the board is normal or not.
- 5) Use the nylon button to bundle the power cables.

Figure C-2 Schematic Diagram for the Ethernet port Arrester Installation



- i** The Ethernet port arrester is only for the 10M/100M copper Ethernet ports with the RJ-45 connector;
- i** The Ethernet port arrester is not provided, the user can purchase them to address their own practical requirements. For the detailed information for the arrester installation, please refer to Ethernet Port Arrester Hardware Installation Guide, which contains the technical specification and the maintenance and installation of the arrester.

You should pay attention to the following conditions during the actual installation to avoid influencing the performance of the Ethernet port arrester:

- Reversed direction of the arrester installation. You shall connect the external network cable to the “IN” end and connect the switch Ethernet port to the “OUT” end.
- Poor arrester grounding. The length of the grounding line should be as short as possible to ensure that it is in good contact with the switch grounding terminal. Use the multimeter to confirm the contact condition after the grounding.
- Incomplete arrester installation. If there is more than one port connected to the peer device on the switch, it entails installation of arresters on all connection ports for the purpose of lightning protection.

## Appendix D Cabling Recommendations in Installation

When the switches are installed in standard 19-inch cabinets, the cables are tied in the binding rack on the cabinet by the cable management bracket, and top cabling or bottom cabling is adopted according to the actual situation in the equipment room. All cable connectors should be placed at the bottom of the cabinet in an orderly manner instead of outside the cabinet easy to touch. Power cables are routed beside the cabinet, and top cabling or bottom cabling is adopted according to the actual situation in the equipment room, such as the position of the DC power distribution box, AC socket, or lightning protection box.

### Requirement for the Minimum Cable Bend Radius

- The bend radius of a power cord, communication cable, and flat cable should be over five times greater than their respective diameters. The bend radius of these cables that often bend or suffer removal/insertion should be over seven times greater than their respective diameters.
- After cabling is fixed, the bend radius of a common coaxial cable should be over seven times greater than its diameter. The bend radius of this type of cables that often bend or suffer removal/insertion should be over 10 times greater than its diameter.
- The bend radius of a high-speed cable (SFP+ cable, for example) should be over five times greater than its diameter. The bend radius of this type of cables that often bend or suffer removal/insertion should be over 10 times greater than its diameter.

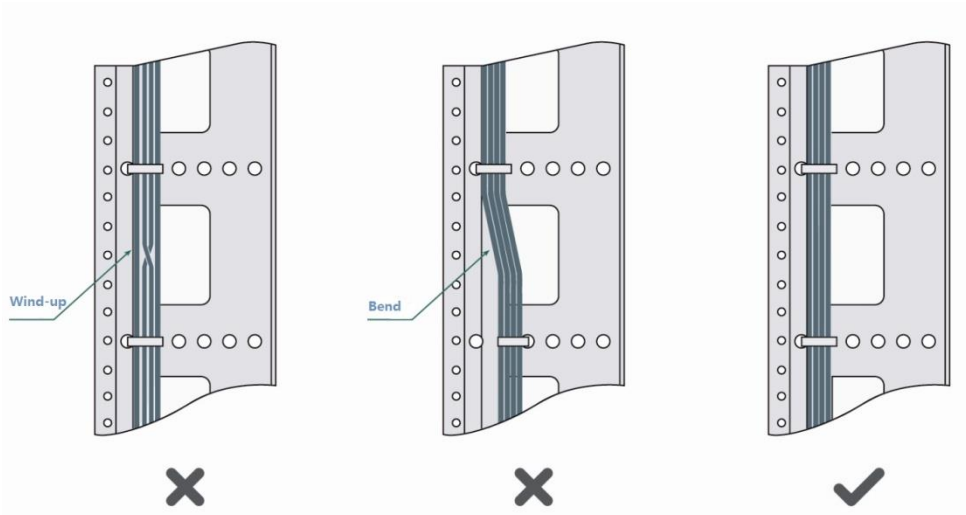
### Requirement for the Minimum Fiber Bend Radius

- The diameter of a fiber tray to hold fibers should be over 25 times greater than the diameter of the fiber.
- When an optical fiber is moved, the bend radius of the fiber should be over 20 times greater than the diameter of the fiber.
- During cabling of an optical fiber, the bend radius of the fiber should be over 10 times greater than the diameter of the fiber.

### Precautions for Bundling up Cables

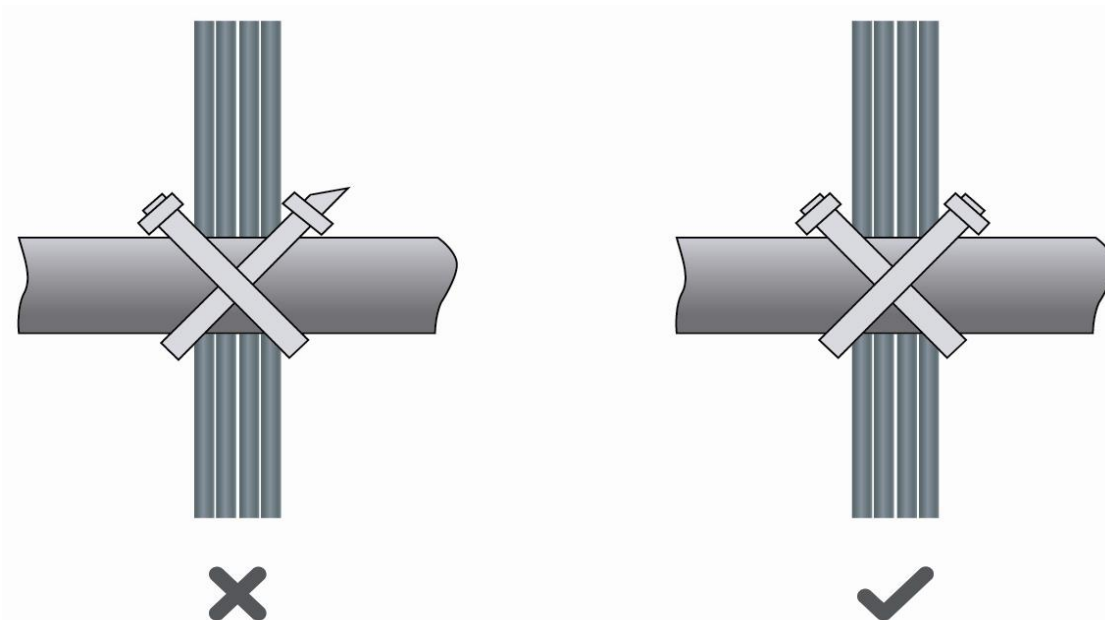
- Before cables are bundled, correctly mark labels and stick the labels to cables wherever appropriate.
- Cables should be neatly and properly bundled, and no twisting or bending is allowed, as shown in Figure D-1.

Figure D-1 Bundling up cables (1)



- Cables of different types (such as power cords, signal cables, and grounding cables) should be separated in cabling and bundling and no mixed bundling is allowed. When they are close, crossover cabling can be adopted. In the case of parallel cabling, power cords and signal cables should maintain a distance not less than 30 mm.
- The binding rack and cabling slot inside and outside the cabinet should be smooth without sharp corners.
- The metal hole traversed by cables should have a smooth and fully rounding surface or an insulated lining.
- Proper buckles should be selected to bundle up cables. It is forbidden to connect two or more buckles to bundle up cables.
- After bundling up cables with buckles, you should cut off the remaining part. The cut should be smooth and trim, without sharp corners, as shown in Figure D-2.

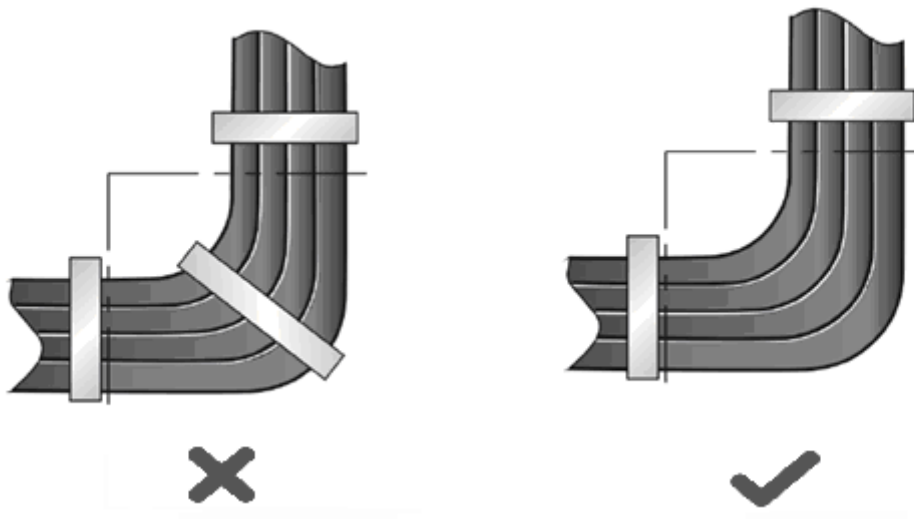
Figure D-2 Bundling up cables (2)



- When cables need to be bent, you should first bundle them up. However, the buckle cannot be bundled within the bend area. Otherwise, considerable stress may be generated in cables, breaking cable cores. As shown in Figure D-3.

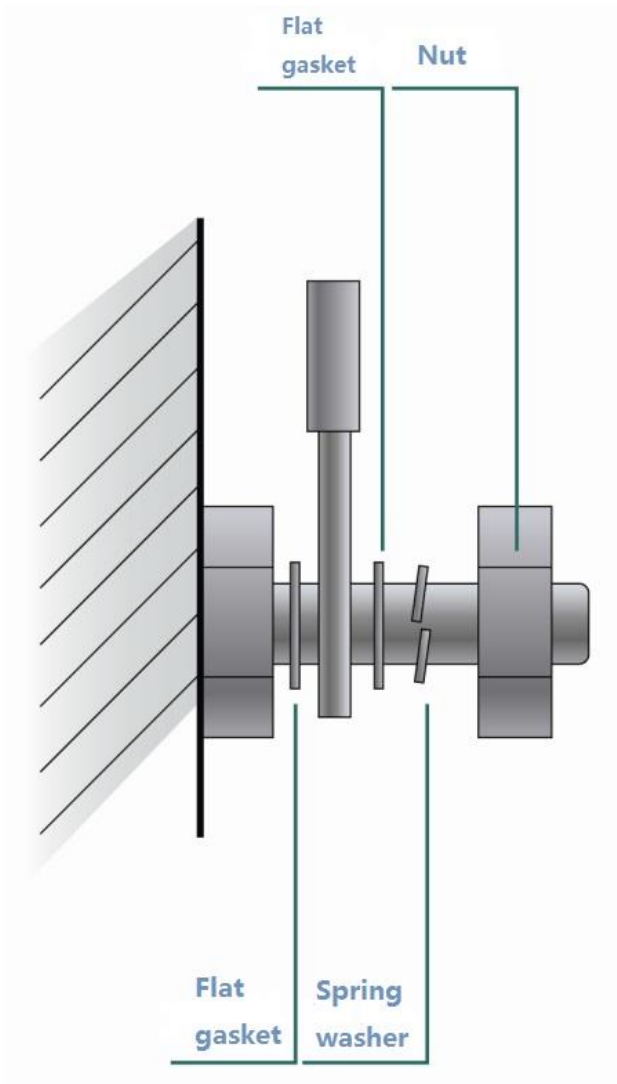


Figure D-3 Bundling up cables (3)



- Cables not to be assembled or remaining parts of cables should be folded and placed in a proper position of the cabinet or cabling slot. The proper position indicates a position that will not affect device running or cause device damage or cable damage during commissioning.
- 220V and -48V power cords cannot be bundled on the guide rails of moving parts.
- The power cables connecting moving parts such as door grounding wires should be reserved with some access after assembled to avoid suffering tension or stress. When the moving part reaches the installation position, the remaining part should not touch heat sources, sharp corners, or sharp edges. If heat sources cannot be avoided, high-temperature cables should be used.
- When using screw threads to fasten cable terminals, the bolt or screw must be tightly fastened, and anti-loosening measures should be taken, as shown in Figure D-4.

Figure D-4 Cable fastening



- The hard power cable should be fastened at the terminal connection area to prevent stress on terminal connection and cable.
- Do not use self-tapping screws to fasten terminals.
- Power cables of the same type and in the same cabling direction should be bundled up into cable bunches, with cables in cable bunches clean and straight.
- Binding by using buckles should be performed according to Table D-1.

Cable Bunch Diameter (mm)	Binding space (mm)
10	80-150
10-30	150-200
30	200-300

- No knot is allowed in cabling or bundling.

For wiring terminal blocks (such as air switches) of the cold pressing terminal type, the metal part of the cold pressing terminal should not be exposed outside the terminal block when assembled.

## Appendix E Site Selection

- The machine room should be at least 5km away from the heavy pollution source such as the smelter, coal mine and thermal power plant, 3.7km away from the medium pollution source such as the chemical industry, rubber industry and electroplating industry, and 2km away from the light pollution source such as the food manufacturer and leather plant. If the pollution source is unavoidable, the machine room should be located on the windward side of the pollution source perennially with advanced protection.
- The machine room should be at least 3.7km away from the sea or salt lake. Otherwise, the machine room must be sealed, with air conditioner installed for temperature control. Saline soil cannot be used for construction. Otherwise, you should select devices with advanced protection against severe environment.
- Do not build the machine room in the proximity of livestock farms. Otherwise, the machine room should be located on the windward side of the pollution source perennially. The previous livestock house or fertilizer warehouse cannot be used as the machine room.
- The machine room should be firm enough to withstand severe weather conditions such as windstorm and heavy rain as well as away from dust. If the dust is unavoidable, keep the door and window away from the pollution source.
- The machine room should be away from the residential area. Otherwise, the machine room should meet the construction standard in terms of noise.
- Make sure the air vent of the machine room is away from the sewage pipe, septic tank, and sewage treatment tank. Keep the machine room under positive pressure to prevent corrosive gas from entering the machine room to corrode components and circuit boards. Keep the machine room away from industrial boiler and heating boiler.
- The machine room had better be on the second floor or above. Otherwise, the machine room floor should be 600mm higher than the highest flood level ever recorded.
- Make sure there are no cracks or holes in the wall and floor. If there are cable entries in the wall or window, take proper sealing measures. Ensure that the wall is flat, wear-resistant, and dust-free, which should be up to the standard for flame retarding, soundproofing, heat absorption, dust reduction, and electromagnetic shielding.
- Keep the door and the window closed to make the machine room sealed.
- The steel door is recommended for soundproofing.
- Sulfur-containing materials are forbidden.
- Pay attention to the location of the air conditioner. Keep the air conditioner from blowing wind straight toward the device or blowing water drops from the window or air vent toward the device.

## Appendix F Ruijie Intelligent Tech Assistant



Scan the QR code to get help.

- Ruijie Networks Intelligent Service: <http://yixiu.ruijie.com.cn:8888/robot/interface/index.html>
- Ruijie Networks Official Website: <https://www.ruijienetworks.com/>
- Ruijie Customer Service: 86-4008-111-000